

EVALUATION KIT
AVAILABLE

MAXIM

5-Channel Slim DSC Power Supplies

General Description

The MAX1584/MAX1585 provide a complete power-supply solution for slim digital cameras. They improve performance, component count, and size compared to conventional multichannel controllers in 2-cell AA, 1-cell Li+, and dual-battery designs. On-chip MOSFETs provide up to 95% efficiency for critical power supplies, while additional channels operate with external FETs for optimum design flexibility. This optimizes overall efficiency and cost, while also reducing board space.

The MAX1584/MAX1585 include 5 high-efficiency DC-DC conversion channels:

- Step-up DC-DC converter with on-chip FETs
- Step-down DC-DC converter with on-chip FETs
- Three PWM DC-DC controllers for CCD, LCD, LED, or other functions

The step-down DC-DC converter can operate directly from the battery or from the step-up output, providing boost-buck capability with a compound efficiency of up to 90%. Both devices include three PWM DC-DC controllers: the MAX1584 includes two step-up controllers and one step-down controller, while the MAX1585 includes one step-up controller, one inverting controller, and one step-down controller. All DC-DC channels operate at one fixed frequency—settable from 100kHz to 1MHz—to optimize size, cost, and efficiency. Other features include soft-start, power-OK outputs, and overload protection. The MAX1584/MAX1585 are available in space-saving, 32-pin thin QFN packages. An evaluation kit is available to expedite designs.

Applications

Digital Cameras
PDAs

Typical Operating Circuit

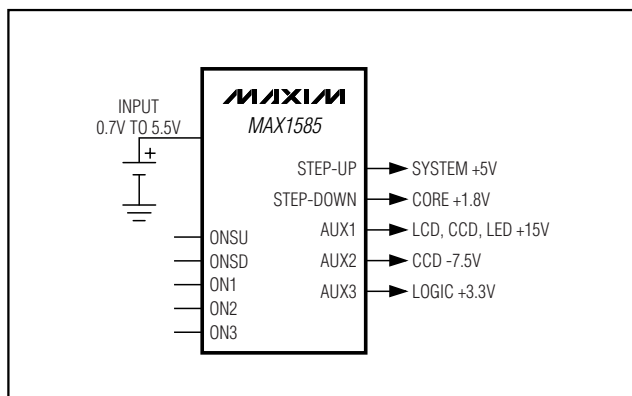

Features

- ◆ Step-Up DC-DC Converter, 95% Efficient
- ◆ Step-Down DC-DC Converter
 - Operate from Battery for 95% Efficient Step-Down
 - 90% Efficient Boost-Buck with Step-Up
- ◆ Three Auxiliary PWM DC-DC Controllers
- ◆ No Transformers (MAX1585)
- ◆ Up to 1MHz Operating Frequency
- ◆ 1mA Shutdown Mode
- ◆ Internal Soft-Start Control
- ◆ Overload Protection
- ◆ Compact 32-Pin Thin QFN Package (5mm x 5mm)

Ordering Information

PART	TEMP RANGE	PIN-PACKAGE	AUX FUNCTIONS
MAX1584ETJ	-40°C to +85°C	32 Thin QFN 5mm x 5mm	2 step-up 1 step-down
MAX1585ETJ	-40°C to +85°C	32 Thin QFN 5mm x 5mm	1 step-up 1 step-down 1 inverting

Pin Configuration

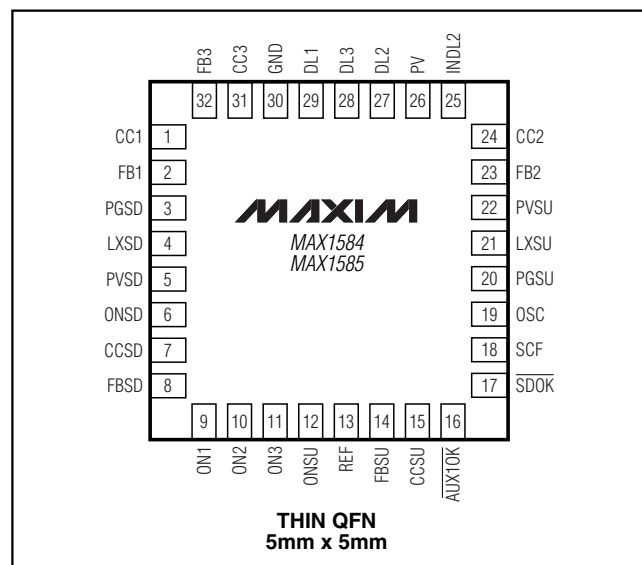

MAXIM

Maxim Integrated Products 1

For pricing, delivery, and ordering information, please contact Maxim/Dallas Direct! at 1-888-629-4642, or visit Maxim's website at www.maxim-ic.com.

MAX1584/MAX1585

5-Channel Slim DSC Power Supplies

ABSOLUTE MAXIMUM RATINGS

PV, PVSU, PVSD, \overline{SDOK} , $\overline{AUX1OK}$, SCF, ON ₋ , FB ₋ to GND.....	-0.3V to +6V
PGND to GND.....	-0.3V to +0.3V
INDL2, DL1, DL3 to GND.....	-0.3V to (PVSU + 0.3V)
DL2 to GND.....	-0.3V to (INDL2 + 0.3V)
PV to PVSU.....	-0.3V to +0.3V
LXSU Current (Note 1).....	3.6A
LXSD Current (Note 1).....	2.25A
REF, OSC, CC ₋ to GND.....	-0.3V to (PVSU + 0.3V)

Continuous Power Dissipation ($T_A = +70^\circ\text{C}$) 32-Pin Thin QFN (derate 22mW/ $^\circ\text{C}$ above $+70^\circ\text{C}$)	1700mW
Operating Temperature Range	-40°C to $+85^\circ\text{C}$
Junction Temperature	$+150^\circ\text{C}$
Storage Temperature Range	-65°C to $+150^\circ\text{C}$
Lead Temperature (soldering, 10s)	$+300^\circ\text{C}$

Note 1: LXSU has internal clamp diodes to PVSU and PGND, and LXSD has internal clamp diodes to PVSD and PGND. Applications that forward bias these diodes should take care not to exceed the device's power dissipation limits.

Stresses beyond those listed under "Absolute Maximum Ratings" may cause permanent damage to the device. These are stress ratings only, and functional operation of the device at these or any other conditions beyond those indicated in the operational sections of the specifications is not implied. Exposure to absolute maximum rating conditions for extended periods may affect device reliability.

ELECTRICAL CHARACTERISTICS

($V_{PVSU} = V_{PV} = V_{PVSD} = V_{INDL2} = 3.6\text{V}$, $T_A = 0^\circ\text{C}$ to $+85^\circ\text{C}$, unless otherwise noted.)

PARAMETER	CONDITIONS	MIN	TYP	MAX	UNITS
GENERAL					
Input Voltage Range	(Note 2)	0.7		5.5	V
Step-Up Minimum Startup Voltage	$I_{LOAD} < 1\text{mA}$, $T_A = +25^\circ\text{C}$, startup voltage tempco is $-2300\text{ppm}/^\circ\text{C}$ (typ) (Note 3)		0.9	1.1	V
Shutdown Supply Current into PV	$PV = 3.6\text{V}$		0.1	5	μA
Supply Current into PV with Step-Up Enabled	$ONSU = 3.6\text{V}$, $FBSU = 1.5\text{V}$ (does not include switching losses)		300	450	μA
Supply Current into PV with Step-Up and Step-Down Enabled	$ONSU = ONSD = 3.6\text{V}$, $FBSU = 1.5\text{V}$, $FBSD = 1.5\text{V}$ (does not include switching losses)		450	700	μA
Total Supply Current from PV and PVSU with Step-Up and One AUX Enabled	$ONSU = ON1 = 3.6\text{V}$, $FBSU = 1.5\text{V}$, $FB2 = 1.5\text{V}$ (does not include switching losses)		400	650	μA
REFERENCE					
Reference Output Voltage	$I_{REF} = 20\mu\text{A}$	1.23	1.25	1.27	V
Reference Load Regulation	$10\mu\text{A} < I_{REF} < 200\mu\text{A}$		4.5	10	mV
Reference Line Regulation	$2.7 < PVSU < 5.5\text{V}$		1.3	5	mV
OSCILLATOR					
OSC Discharge Trip Level	Rising edge	1.225	1.25	1.275	V
OSC Discharge Resistance	$OSC = 1.5\text{V}$, $I_{OSC} = 3\text{mA}$		52	80	Ω
OSC Discharge Pulse Width			150		ns
OSC Frequency	$R_{OSC} = 47\text{k}\Omega$, $C_{OSC} = 100\text{pF}$		500		kHz
STEP-UP DC-DC CONVERTER					
Step-Up Startup-to-Normal Operating Threshold	Rising edge or falling edge (Note 4)	2.30	2.5	2.65	V
Step-Up Startup-to-Normal Operating Threshold Hysteresis			80		mV

5-Channel Slim DSC Power Supplies

MAX1584/MAX1585

ELECTRICAL CHARACTERISTICS (continued)

(VPVSU = VPV = VPVSD = VINDL2 = 3.6V, TA = 0°C to +85°C, unless otherwise noted.)

PARAMETER	CONDITIONS	MIN	TYP	MAX	UNITS
Step-Up Voltage Adjust Range		3.0		5.5	V
Start Delay of ONSD, ON1, ON2, ON3 after SU in Regulation			1024		OSC cycles
FBSU Regulation Voltage		1.231	1.25	1.269	V
FBSU to CCSU Transconductance	FBSU = CCSU	80	135	185	μS
FBSU Input Leakage Current	FBSU = 1.25V	-100	+1	+100	nA
Idle Mode™ Trip Level	(Note 6)		150		mA
Current-Sense Amplifier Transresistance			0.275		V/A
Step-Up Maximum Duty Cycle	FBSU = 1V	80	85	90	%
PVSU Leakage Current	VLX = 0V, PVSU = 5.5V		0.1	5	μA
LXSU Leakage Current	VLXSU = VOUT = 5.5V		0.1	5	μA
Switch On-Resistance	N channel		95	150	mΩ
	P channel		150	250	
N-Channel Current Limit		2.4	2.8	3.2	A
P-Channel Turn-Off Current			20		mA
Startup Current Limit	PVSU = 1.8V (Note 5)		450		mA
Startup tOFF	PVSU = 1.8V		700		ns
Startup Frequency	PVSU = 1.8V		200		kHz
STEP-DOWN DC-DC CONVERTER					
Step-Down Output Voltage Adjust Range	PVSD must be greater than output (Note 7)	1.25		5.00	V
FBSD Regulation Voltage		1.231	1.25	1.269	V
FBSD to CCSD Transconductance	FBSD = CCSD	80	135	185	μS
FBSD Input Leakage Current	FBSD = 1.25V	-100	+0.1	+100	nA
Idle Mode Trip Level	(Note 6)		100		mA
Current-Sense Amplifier Transresistance			0.5		V/A
LXSD Leakage Current	VLXSD = 0 to 3.6V, PVSU = 3.6V		0.1	5	μA
Switch On-Resistance	N channel		95	150	mΩ
	P channel		150	250	
P-Channel Current Limit		0.65	0.8	0.95	A
N-Channel Turn-Off Current			20		mA
Soft-Start Interval			2048		OSC cycles
SDOK Output Low Voltage	0.1mA into SDOK		0.01	0.1	V
SDOK Leakage Current	ONSU = GND		0.01	1	μA

Idle Mode is a trademark of Maxim Integrated Products, Inc.

5-Channel Slim DSC Power Supplies

ELECTRICAL CHARACTERISTICS (continued)

($V_{PVSU} = V_{PV} = V_{PVSD} = V_{INDL2} = 3.6V$, $T_A = 0^\circ C$ to $+85^\circ C$, unless otherwise noted.)

PARAMETER	CONDITIONS	MIN	TYP	MAX	UNITS
AUX1, 2, 3 DC-DC CONTROLLERS					
Maximum Duty Cycle	FB_ = 1V	80	85	90	%
FB1 and FB3 Regulation Voltage	FB_ = CC_	1.231	1.25	1.269	V
FB2 (MAX1584) Regulation Voltage	FB_ = CC_	1.231	1.25	1.269	V
FB2 (MAX1585) (Inverter) Regulation Voltage	FB_ = CC_	-0.01	0	+0.01	V
FB_ to CC_ Transconductance	FB_ = CC_	80	135	185	μS
FB_ Input Leakage Current	FB_ = 1.25V	-100	+1	+100	nA
DL_ Driver Resistance	Output high or low		2.5	10	Ω
DL_ Drive Current	Sourcing or sinking		0.5		A
Soft-Start Interval			4096		OSC cycles
AUX1OK Output Low Voltage	0.1mA into $\overline{AUX1OK}$		0.01	0.1	V
AUX1OK Leakage Current	ONSU = GND		0.01	1	μA
OVERLOAD AND THERMAL PROTECTION					
Overload-Protection Fault Delay			100,000		OSC cycles
SCF Leakage Current	ONSU = PVSU, FBSU = 1.5V		0.1	1	μA
SCF Output Low Voltage	0.1mA into SCF		0.01	0.1	V
Thermal Shutdown			+160		$^\circ C$
Thermal Hysteresis			20		$^\circ C$
LOGIC INPUTS					
ON_ Input Low Level	1.1V < PVSU < 1.8V (ONSU only)			0.2	V
	1.8V < PVSU < 5.5V			0.4	
ON_ Input High Level	1.1V < PVSU < 1.8V (ONSU only)	$V_{PVSU} - 0.2$			V
	1.8V < PVSU < 5.5V	1.6			
ON_ Impedance to GND	ON_ = 3.35V		330		k Ω

5-Channel Slim DSC Power Supplies

MAX1584/MAX1585

ELECTRICAL CHARACTERISTICS

($V_{PVSU} = V_{PV} = V_{PVSD} = V_{INDL2} = 3.6V$, $T_A = -40^{\circ}C$ to $+85^{\circ}C$, unless otherwise noted.) (Note 8)

PARAMETER	CONDITIONS	MIN	MAX	UNITS
GENERAL				
Input Voltage Range	(Note 2)	0.7	5.5	V
Shutdown Supply Current into PVSU	PVSU = 3.6V		5	μA
Supply Current into PV with Step-Up Enabled	ONSU = 3.6V, FBSU = 1.5V (does not include switching losses)		450	μA
Supply Current into PV with Step-Up and Step-Down Enabled	ONSU = ONSD = 3.6V, FBSU = 1.5V, FBSD = 1.5V (does not include switching losses)		700	μA
Total Supply Current from PV and PVSU with Step-Up and One AUX Enabled	ONSU = ON1 = 3.6V, FBSU = 1.5V, FB2 = 1.5V (does not include switching losses)		650	μA
REFERENCE				
Reference Output Voltage	$I_{REF} = 20\mu A$	1.225	1.275	V
Reference Load Regulation	$10\mu A < I_{REF} < 200\mu A$		10	mV
Reference Line Regulation	$2.7V < PVSU < 5.5V$		5	mV
OSCILLATOR				
OSC Discharge Trip Level	Rising edge	1.225	1.275	V
OSC Discharge Resistance	OSC = 1.5V, $I_{OSC} = 3mA$		80	Ω
STEP-UP DC-DC CONVERTER				
Step-Up Startup-to-Normal Operating Threshold	Rising edge or falling edge (Note 4)	2.30	2.65	V
Step-Up Voltage Adjust Range		3.0	5.5	V
FBSU Regulation Voltage		1.225	1.275	V
FBSU to CCSU Transconductance	FBSU = CCSU	80	185	μS
FBSU Input Leakage Current	FBSU = 1.25V	-100	+100	nA
Step-Up Maximum Duty Cycle	FBSU = 1V	80	90	%
PVSU Leakage Current	$V_{LX} = 0V$, PVSU = 5.5V		5	μA
LXSU Leakage Current	$V_{LXSU} = V_{OUT} = 5.5V$		5	μA
Switch On-Resistance	N channel		150	m Ω
	P channel		250	
N-Channel Current Limit		2.4	3.2	A
STEP-DOWN DC-DC CONVERTER				
Step-Down Output Voltage Adjust Range	PVSD must be greater than output (Note 7)	1.25	5.00	V

5-Channel Slim DSC Power Supplies

ELECTRICAL CHARACTERISTICS (continued)

($V_{PVSU} = V_{PV} = V_{PVSD} = V_{INDL2} = 3.6V$, $T_A = -40^{\circ}C$ to $+85^{\circ}C$, unless otherwise noted.) (Note 8)

PARAMETER	CONDITIONS	MIN	MAX	UNITS
FBSD Regulation Voltage		1.225	1.275	V
FBSD to CCSD Transconductance	FBSD = CCSD	80	185	μS
FBSD Input Leakage Current	FBSD = 1.25V	-100	+100	nA
LXSD Leakage Current	$V_{LXSD} = 0$ to 3.6V, PVSU = 3.6V		5	μA
Switch On-Resistance	N channel		150	m Ω
	P channel		250	
P-Channel Current Limit		0.65	0.95	A
\overline{SDOK} Output Low Voltage	0.1mA into \overline{SDOK}		0.1	V
\overline{SDOK} Leakage Current	ONSU = GND		1	μA
AUX1, 2, 3 DC-DC CONTROLLERS				
Maximum Duty Cycle	FB_ = 1V	80	90	%
FB1 and FB3 Regulation Voltage	FB_ = CC_	1.225	1.275	V
FB2 (MAX1584) Regulation Voltage	FB_ = CC_	1.225	1.275	V
FB2 (MAX1585) (Inverter) Regulation Voltage	FB_ = CC_	-0.01	+0.01	V
FB_ to CC_ Transconductance	FB_ = CC_	80	185	μS
FB_ Input Leakage Current	FB_ = 1.25V	-100	+100	nA
DL_ Driver Resistance	Output high or low		10	Ω
$\overline{AUX1OK}$ Output Low Voltage	0.1mA into $\overline{AUX1OK}$		0.1	V
$\overline{AUX1OK}$ Leakage Current	ONSU = GND		1	μA
OVERLOAD AND THERMAL PROTECTION				
SCF Leakage Current	ONSU = PVSU, FBSU = 1.5V		1	μA
SCF Output Low Voltage	0.1mA into SCF		0.1	V
LOGIC INPUTS				
ON_ Input Low Level	1.1V < PVSU < 1.8V (ONSU only)		0.2	V
	1.8V < PVSU < 5.5V		0.4	
ON_ Input High Level	1.1V < PVSU < 1.8V (ONSU only)	$V_{PVSU} - 0.2$		V
	1.8V < PVSU < 5.5V	1.6		

Note 2: The MAX1584/MAX1585 are powered from the step-up output (PVSU). An internal low-voltage startup oscillator drives the step-up starting at about 0.9V until PVSU reaches approximately 2.5V. When PVSU reaches 2.5V, the main control circuitry takes over. Once the step-up is up and running, it can maintain operation with very low input voltages; however, output current is limited.

Note 3: Since the device is powered from PVSU, a Schottky rectifier, connected from the input battery to PVSU, is required for low-voltage startup, or if PVSD is connected to V_{IN} instead of PVSU.

Note 4: The step-up regulator is in startup mode until this voltage is reached. Do not apply full load current during startup. A power-OK output can be used with an external PFET to gate the load until the step-up is in regulation. See the *Applications Information* section.

5-Channel Slim DSC Power Supplies

MAX1584/MAX1585

ELECTRICAL CHARACTERISTICS (continued)

($V_{PVSU} = V_{PV} = V_{PVSD} = V_{INDL2} = 3.6V$, $T_A = -40^{\circ}C$ to $+85^{\circ}C$, unless otherwise noted.) (Note 8)

Note 5: The step-up current limit in startup refers to the LXSU switch current limit, not an output current limit.

Note 6: The idle mode current threshold is the transition point between fixed-frequency PWM operation and idle mode operation (where switching rate varies with load). The specification is given in terms of inductor current. In terms of output current, the idle mode transition varies with input-output voltage ratio and inductor value. For the step-up, the transition output current is approximately 1/3 the inductor current when stepping from 2V to 3.3V. For the step-down, the transition current in terms of output current is approximately 3/4 the inductor current when stepping down from 3.3V to 1.8V.

Note 7: Operation in dropout (100% duty cycle) can only be maintained for 100,000 OSC cycles before the output is considered faulted, triggering global shutdown.

Note 8: Specifications to $-40^{\circ}C$ are guaranteed by design, not production tested.

Typical Operating Characteristics

(Circuit of Figure 1, $T_A = +25^{\circ}C$, unless otherwise noted.)

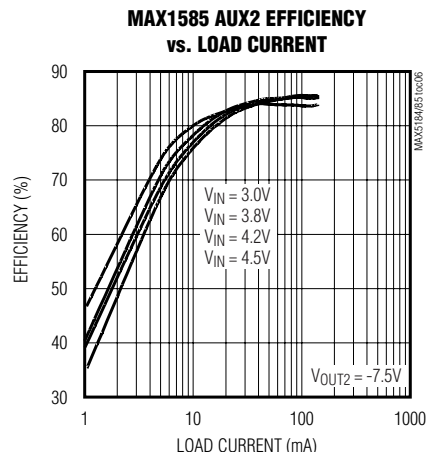
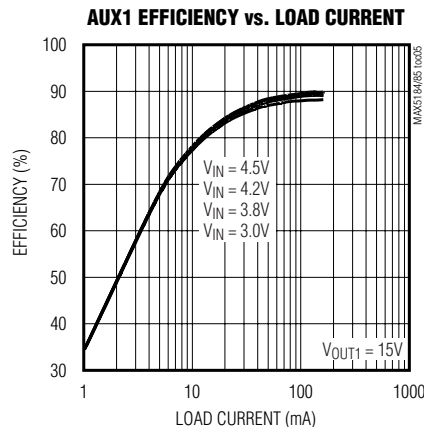
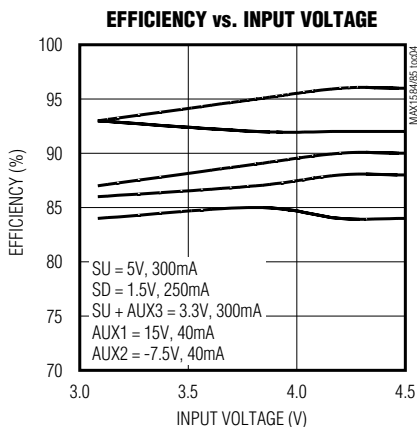
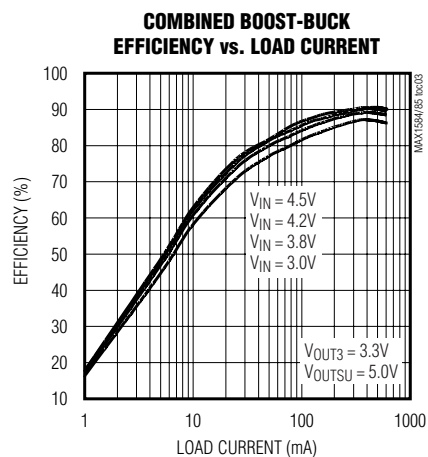
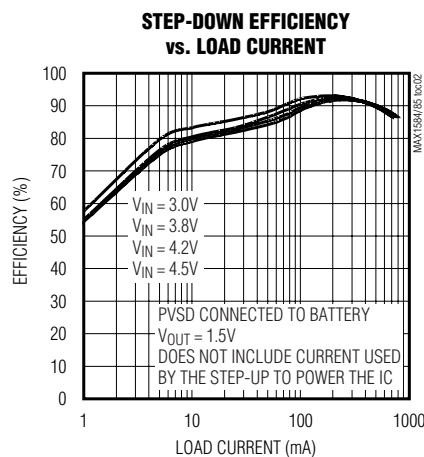
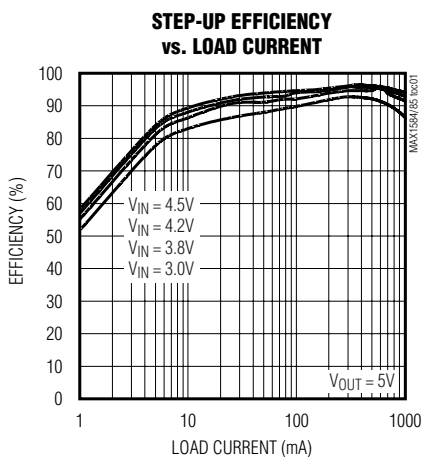

5-Channel Slim DSC Power Supplies

Typical Operating Characteristics (continued)

(Circuit of Figure 1, $T_A = +25^\circ\text{C}$, unless otherwise noted.)

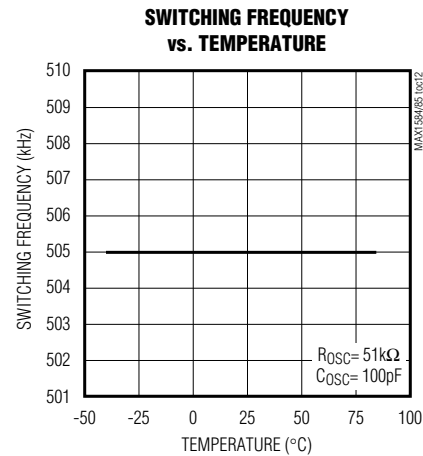
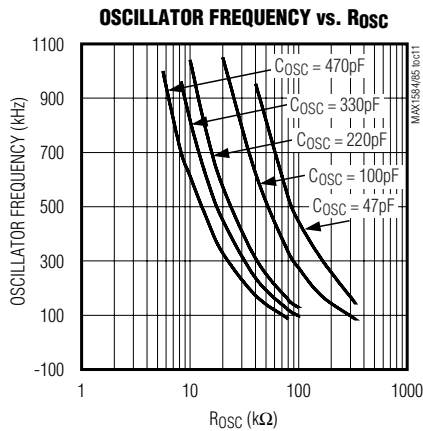
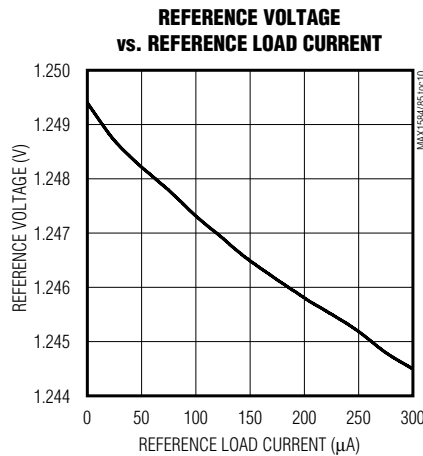
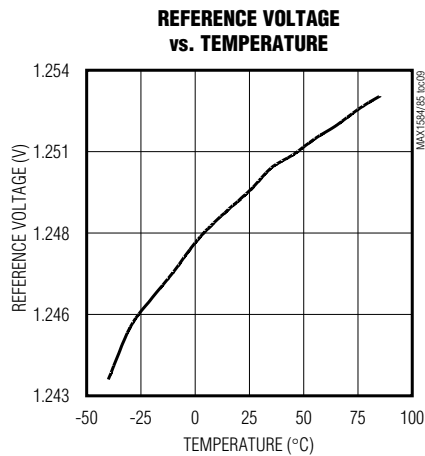
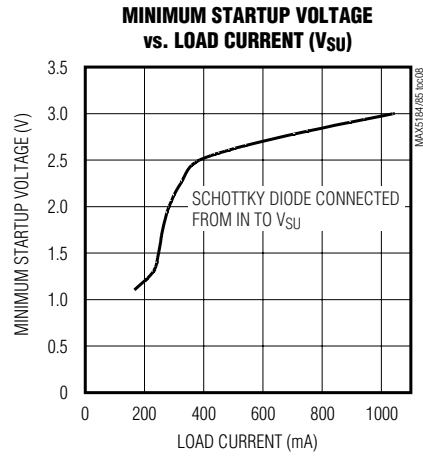
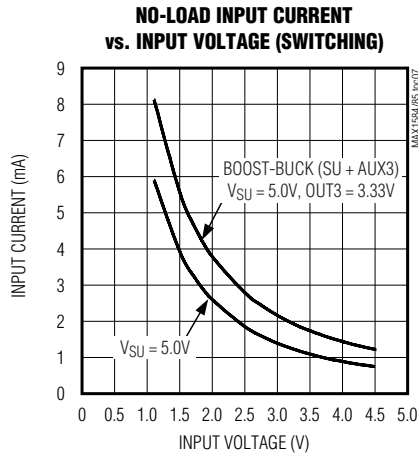

5-Channel Slim DSC Power Supplies

Typical Operating Characteristics (continued)

(Circuit of Figure 1, $T_A = +25^\circ\text{C}$, unless otherwise noted.)

MAX1584/MAX1585

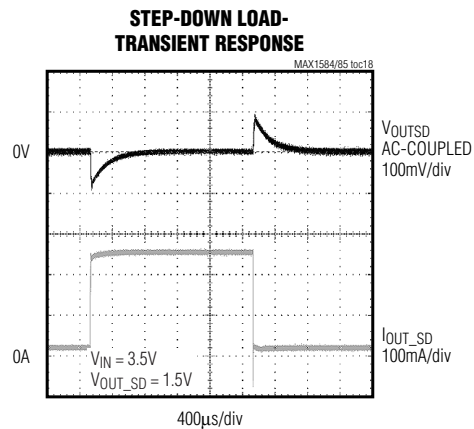
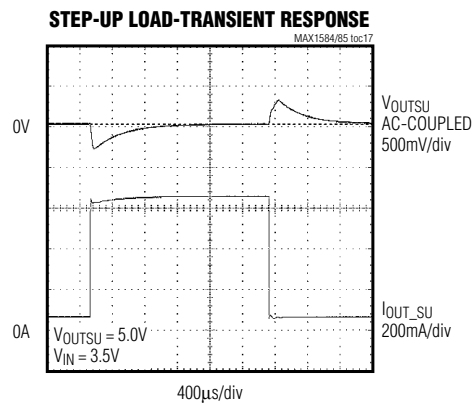
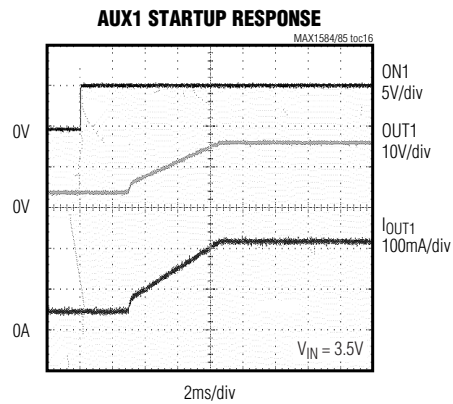
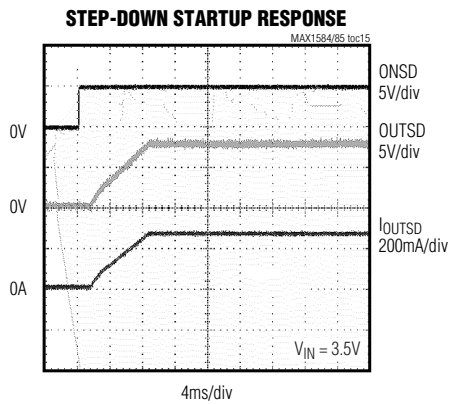
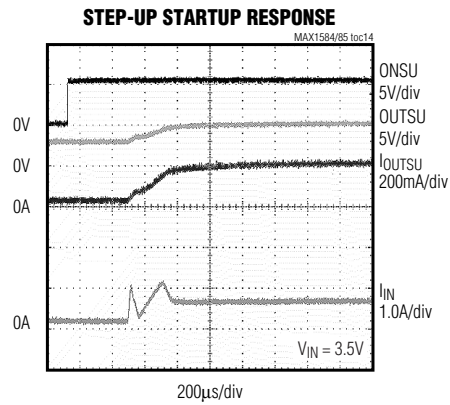
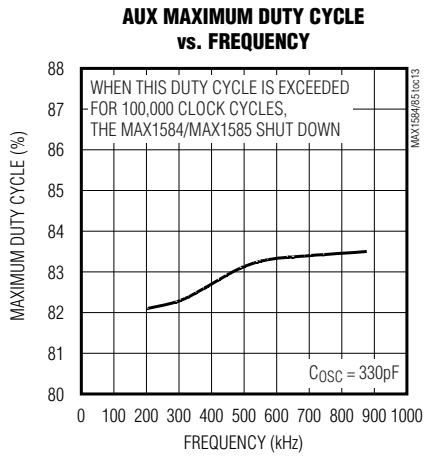

5-Channel Slim DSC Power Supplies

Pin Description

PIN	NAME	FUNCTION
1	CC1	AUX1 Controller Compensation Node. Connect a series resistor-capacitor from CC1 to GND to compensate the converter control loop. This pin is actively driven to GND in shutdown, overload, and thermal limit. See the <i>AUX Compensation</i> section.
2	FB1	AUX1 Controller Feedback Input. The feedback threshold is 1.25V. This pin is high impedance in shutdown.
3	PGSD	Step-Down Power Ground. Connect all PG_ pins together and to GND with short traces as close as possible to the IC.
4	LXSD	Step-Down Converter Switching Node. Connect to the inductor of the step-down converter. LXSD is high impedance in shutdown.
5	PVSD	Step-Down Converter Input. PVSD can connect to PVSU, effectively making OUTSD a boost-buck output from the battery. Bypass to GND with a 1 μ F ceramic capacitor if connected to PVSU. PVSD can also be connected to the battery but should not exceed PVSU by more than a Schottky diode forward voltage. Bypass PVSD with a 10 μ F ceramic capacitor when connecting to the battery input. A 10k Ω internal resistance connects PVSU and PVSD.
6	ONSD	Step-Down Converter On/Off Control Input. Logic high = on; however, turn-on is locked out until the step-up has reached regulation. This pin has an internal 330k Ω pull-down resistance to GND.
7	CCSD	Step-Up Converter Compensation Node. Connect a series resistor-capacitor from CCSD to GND to compensate the converter control loop. This pin is actively driven to GND in shutdown, overload, and thermal limit. See the <i>Step-Down Compensation</i> section.
8	FBSD	Step-Down Converter Feedback Input. Connect a resistive voltage-divider from OUTSD to FBSD to GND. The FBSD feedback threshold is 1.25V. This pin is high impedance in shutdown.
9	ON1	AUX1 Controller On/Off Input. Logic high = on; however, turn-on is locked out until 1024 OSC cycles after the step-up has reached regulation. This pin has an internal 330k Ω pull-down resistance to GND.
10	ON2	AUX2 Controller On/Off Input. Logic high = on; however, turn-on is locked out until 1024 OSC cycles after the step-up has reached regulation. This pin has an internal 330k Ω pull-down resistance to GND.
11	ON3	AUX3 Controller On/Off Input. Logic high = on; however, turn-on is locked out until 1024 OSC cycles after the step-up has reached regulation. This pin has an internal 330k Ω pull-down resistance to GND.
12	ONSU	Step-Up Converter On/Off Control. Logic high = on. All other ON_ pins are locked out until 1024 OSC cycles after the step-up DC-DC converter output has reached its final value. This pin has an internal 330k Ω pull-down resistance to GND.
13	REF	Reference Output. Bypass REF to GND with a 0.1 μ F or greater capacitor. The maximum allowed load on REF is 200 μ A. REF is actively pulled to GND when all converters are shut down.
14	FBSU	Step-Up Converter Feedback Input. Connect a resistive voltage-divider from PVSU to FBSU to GND. The FBSU feedback threshold is 1.25V. This pin is high impedance in shutdown.
15	CCSU	Step-Up Converter Compensation Node. Connect a series resistor-capacitor from CCSU to GND to compensate the converter control loop. This pin is actively driven to GND in shutdown, overload, and thermal limit. See the <i>Step-Up Compensation</i> section.

5-Channel Slim DSC Power Supplies

Pin Description (continued)

MAX1584/MAX1585

PIN	NAME	FUNCTION	
16	$\overline{\text{AUX1OK}}$	Open-Drain Power-OK Signal for AUX1 Controller. $\overline{\text{AUX1OK}}$ is low when the AUX1 controller has successfully completed soft-start. This pin is high impedance in shutdown, overload, and thermal limit.	
17	$\overline{\text{SDOK}}$	Open-Drain Power-OK Signal for Step-Down Converter. $\overline{\text{SDOK}}$ is low when the step-down has successfully completed soft-start. This pin is high impedance in shutdown, overload, and thermal limit.	
18	SCF	Short-Circuit Flag, Active-Low, Open-Drain Output. SCF is high impedance when overload protection occurs and during startup. SCF can drive high-side PFET switches connected to one or more outputs to completely disconnect the load when the channel turns off in response to a logic command or an overload. See the <i>Status Outputs</i> ($\overline{\text{SDOK}}$, $\overline{\text{AUX1OK}}$, $\overline{\text{SCF}}$) section.	
19	OSC	Oscillator Control. Connect a timing capacitor from OSC to GND and a timing resistor from OSC to PVSU (or other DC voltage) to set the oscillator frequency between 100kHz and 1MHz. See the <i>Setting the Switching Frequency</i> section. This pin is high impedance in shutdown.	
20	PGSU	Step-Up Power Ground. Connect all PG_ pins together and to GND with short traces as close to the IC as possible.	
21	LXSU	Step-Up Converter Switching Node. Connect to the inductor of the step-up converter. LXSU is high impedance in shutdown.	
22	PVSU	Power Output of the Step-Up DC-DC Converter. Connect the output filter capacitor from PVSU to PGSU. PVSU can also power other converter channels. Connect PVSU to PV at the IC.	
23	FB2	AUX2 Controller Feedback Input. This pin is high impedance in shutdown.	MAX1585 (AUX2 inverter): The FB2 feedback threshold is 0V. Connect a resistive voltage-divider from the output voltage to FB2 to REF to set the output voltage.
			MAX1584 (AUX2 step-up): The FB2 feedback threshold is 1.25V. Connect a resistive voltage-divider from the output voltage to FB2 to GND to set the output voltage.
24	CC2	AUX2 Controller Compensation Node. Connect a series resistor-capacitor from CC2 to GND to compensate the control loop. CC2 is actively driven to GND in shutdown and thermal limit. See the <i>AUX Compensation</i> section.	
25	INDL2	Voltage Input for the AUX2 Gate Driver. The voltage at INDL2 sets the high gate-drive voltage.	MAX1585 (AUX2 inverter): Connect INDL2 to the external P channel MOSFET source (typically the battery) to ensure the P channel is completely off when D2 swings high.
			MAX1584 (AUX2 step-up): Connect INDL2 to PVSU for optimum N-channel gate drive.
26	PV	IC Power Input. Connect PVSU and PV together.	
27	DL2	AUX2 Controller Gate-Drive Output. DL2 drives between INDL2 and GND.	MAX1585: DL2 drives a PFET in an inverter configuration. In shutdown, overload, and thermal limit, DL2 is driven high.
			MAX1584: DL2 drives an N-channel FET in a boost/flyback configuration. In shutdown, overload, and thermal limit, DL2 is driven low.

5-Channel Slim DSC Power Supplies

Pin Description (continued)

PIN	NAME	FUNCTION
28	DL3	AUX3 Step-Down Controller Gate-Drive Output. Connect to the gate of a P-channel MOSFET. DL3 swings from GND to PVSU and supplies up to 500mA. DL3 is driven to PVSU in shutdown and thermal limit.
29	DL1	AUX1 Step-Up Controller Gate-Drive Output. Connect to the gate of an N-channel MOSFET. DL1 swings from GND to PVSU and supplies up to 500mA. DL1 is driven to GND in shutdown and thermal limit.
30	GND	Analog Ground. Connect to all PG_ pins as close to the IC as possible.
31	CC3	AUX3 Step-Down Controller Compensation Node. Connect a series resistor-capacitor from CC3 to FB3 to compensate the converter control loop. This pin is actively driven to GND in shutdown, overload, and thermal limit. See the <i>AUX Compensation</i> section.
32	FB3	PWM Step-Up Controller 3 Feedback Input. Connect a resistive voltage-divider from the output voltage to FB3 to GND to set the output voltage. The FB3 feedback threshold is 1.25V. This pin is high impedance in shutdown.
PAD	EP	Exposed Underside Metal Pad. This pad must be soldered to the PC board to achieve package thermal and mechanical ratings. There is no internal metal or bond wire physically connecting the exposed pad to the GND pin(s). Connecting the exposed pad to ground does not remove the requirement for a good ground connection to the appropriate IC pins.

Detailed Description

The MAX1584/MAX1585 are complete power-conversion ICs for slim digital still cameras. They can accept input from a variety of sources, including single-cell Li+ batteries and 2-cell alkaline or NiMH batteries, as well as systems designed to accept both battery types. The MAX1584/MAX1585 include five DC-DC converter channels to generate all required voltages (Figure 2 shows a functional diagram):

- Synchronous-rectified step-up DC-DC converter with on-chip MOSFETs—Typically supplies 3.3V for main system power or 5V to power other DC-DC converters for boost-buck designs.
- Synchronous-rectified step-down DC-DC converter with on-chip MOSFETs—Typically supplies 1.8V for the DSP core. Powering the step-down from the step-up output provides efficient (up to 90%) boost-buck functionality that supplies a regulated output when the battery voltage is above or below the output voltage. The step-down can also be powered from the battery if there is sufficient headroom.
- AUX1 step-up controller—Typically used for 15V to bias one or more of the LCD, CCD, and LED backlights.

- AUX2 step-up controller (MAX1584)—Typically supplies remaining bias voltages with either a multi-output flyback transformer or a boost converter with charge-pump inverter. Alternately, can power white LEDs for LCD backlighting.
- AUX2 inverter controller (MAX1585)—Typically supplies negative CCD bias when high current is needed for large pixel-count CCDs.
- AUX3 step-down controller—Typically steps 5V generated at PVSU down to 3.3V for system logic in boost-buck designs.

Step-Up DC-DC Converter

The step-up DC-DC switching converter is typically used to generate a 5V output voltage from a 1.5V to 4.5V battery input, but any voltage from V_{IN} to 5V can be set. An internal NFET switch and a PFET synchronous rectifier allow conversion efficiencies as high as 95%. Under moderate to heavy loading, the converter operates in a low-noise PWM mode with constant frequency and modulated pulse width. Switching harmonics generated by fixed-frequency operation are consistent and easily filtered. Efficiency is enhanced under light (<75mA typ) loading, by an idle mode that switches the step-up only as needed to service the load. In this mode, the maximum inductor current is 250mA for each pulse.

5-Channel Slim DSC Power Supplies

MAX1584/MAX1585

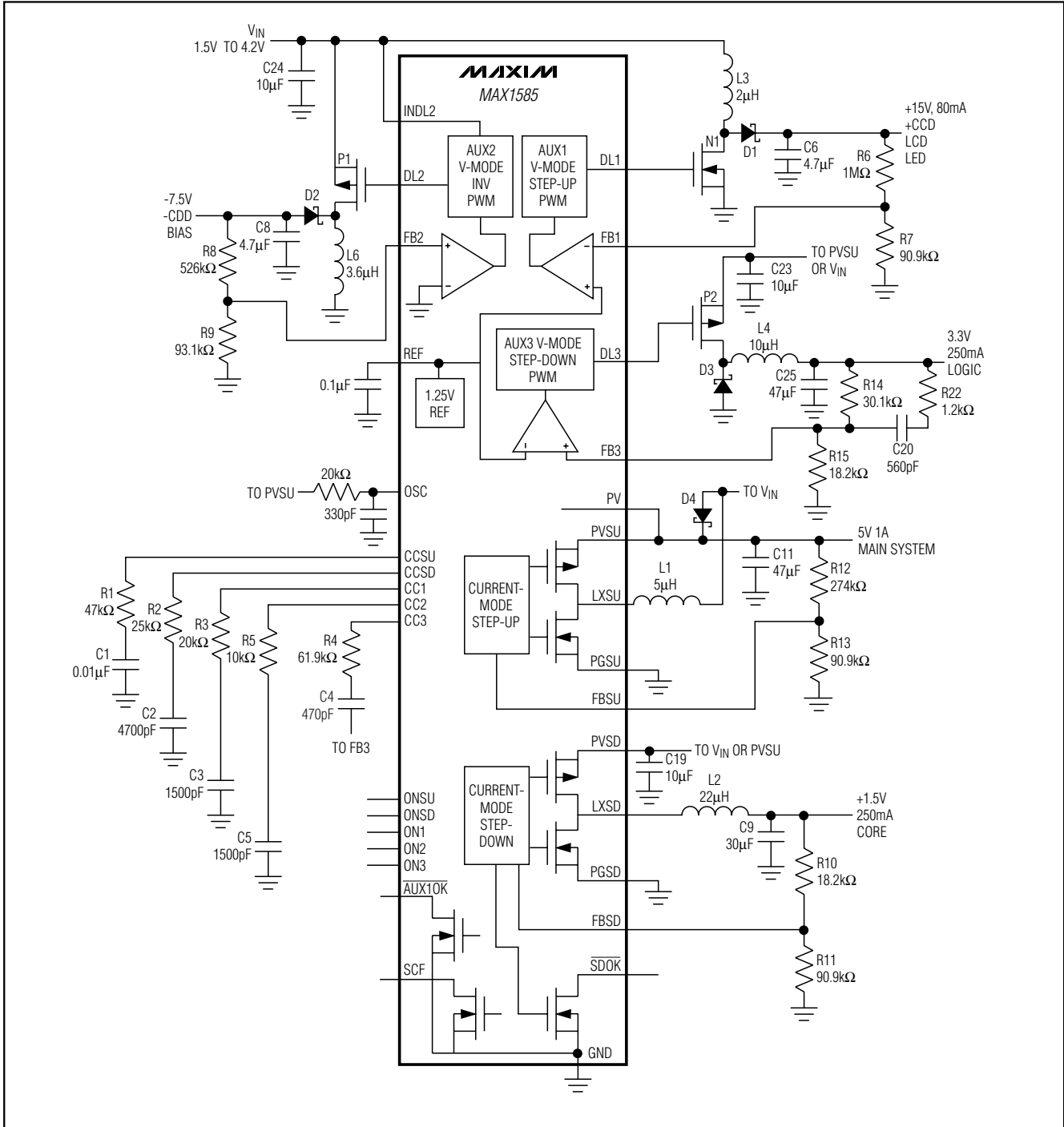

Figure 1. MAX1584/MAX1585 Typical Application for 2-Cell AA or 1-Cell Li+ Battery

5-Channel Slim DSC Power Supplies

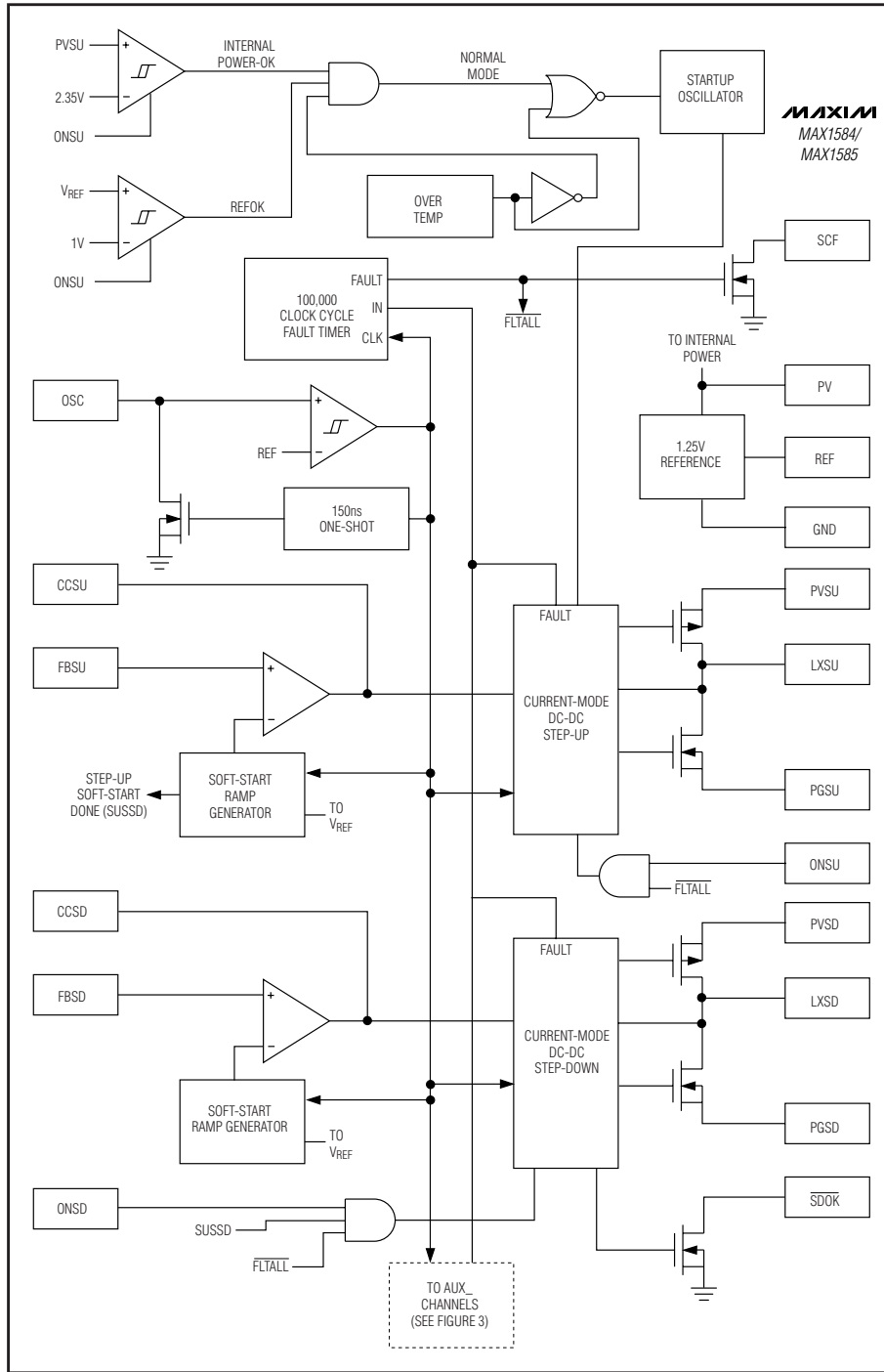

Figure 2. MAX1584/MAX1585 Functional Diagram

5-Channel Slim DSC Power Supplies

Step-Down DC-DC Converter

The step-down DC-DC converter is optimized for generating low output voltages (down to 1.25V) at high efficiency. Output voltages lower than 1V can be set by adding an additional resistor (see the *Applications Information* section). The step-down runs from the voltage at PVSD. This pin can be connected directly to the battery if sufficient headroom exists to avoid dropout; otherwise, PVSD can be powered from the output of another converter. The step-down can also operate with the step-up for boost-buck operation.

Under moderate to heavy loading, the converter operates in a low-noise PWM mode with constant frequency and modulated pulse width. Efficiency is enhanced under light (<75mA typ) loading by assuming an idle mode during which the step-down switches only as needed to service the load. In this mode, the maximum inductor current is 100mA for each pulse. The step-down DC-DC is inactive until the step-up DC-DC is in regulation.

The step-down also features an open-drain $\overline{\text{SDOK}}$ output that goes low when the step-down output is in regulation. $\overline{\text{SDOK}}$ can be used to drive an external MOSFET switch that gates 3.3V power to the processor after the core voltage is in regulation. This connection is shown in Figure 13.

Boost-Buck Operation

The step-down input can be powered from the output of the step-up. By cascading these two channels, the step-down output can maintain regulation even as the battery voltage falls below the step-down output voltage. This is especially useful when trying to generate 3.3V from 1-cell Li+ inputs, or 2.5V from 2-cell alkaline or NiMH inputs, or when designing a power supply that must operate from both Li+ and alkaline/NiMH inputs. Compound efficiencies of up to 90% can be achieved when the step-up and step-down are operated in series.

Note that the step-up output supplies both the step-up load and the step-down input current when the step-down is powered from the step-up. The step-down input current reduces the available step-up output current for other loads.

Direct Battery Step-Down Operation

The step-down converter can also be operated directly from the battery as long as the voltage at PVSD does not exceed PVSU by more than a Schottky diode forward voltage. When using this connection, connect an external Schottky diode from the battery input to PVSU. On the MAX1584/MAX1585, there is an internal 10k Ω resistance from PVSU to PVSD. This adds a small addi-

tional current drain (of approximately $(V_{\text{PVSU}} - V_{\text{PVSD}}) / 10\text{k}\Omega$) from PVSU when PVSD is not connected directly to PVSU.

Step-down direct battery operation improves efficiency for the step-down output (up to 95%), but restricts the upper limit of the output voltage to 200mV less than the minimum battery voltage. In 1-cell Li+ designs (with a 2.7V min), the output can be set up to 2.5V. In 2-cell alkaline or NiMH designs, the output can be limited to 1.5V or 1.8V, depending on the minimum-allowed cell voltage.

The step-down can only be briefly operated in dropout since the MAX1584/MAX1585 fault protection detects the out-of-regulation condition and activates after 100,000 OSC cycles (200ms at $f_{\text{OSC}} = 500\text{kHz}$). At that point, all MAX1584/MAX1585 channels shut down.

AUX1, AUX2, and AUX3 DC-DC Controllers

The three auxiliary controllers operate as fixed-frequency voltage-mode PWM controllers. They do not have internal MOSFETs, so output power is determined by external components. The controllers regulate output voltage by modulating the pulse width of the DL_ drive signal to an external MOSFET switch. The MAX1584 contains two step-up/flyback controllers (AUX1 and AUX2) and one step-down controller (AUX3). The MAX1585 contains one step-up controller (AUX1), one inverting controller (AUX2), and one step-down controller (AUX3).

Figure 3 shows a functional diagram of the AUX controllers. The inverting and step-down controllers differ from the step-up controllers only in the gate-drive logic and FB polarity and threshold. The sawtooth oscillator signal at OSC governs timing. At the start of each cycle, DL_ turns on the external MOSFET switch. For step-up controllers, DL_ goes high, while for inverting and step-down controllers, DL_ goes low (to turn on PFETs). The external MOSFET then turns off when the internally level-shifted sawtooth rises above CC_ or when the maximum duty cycle is exceeded. The switch remains off until the start of the next cycle. A transconductance error amplifier forms an integrator at CC_ so that high DC loop gain and accuracy can be maintained. In step-up and step-down controllers, the FB_ threshold is 1.25V, and higher FB_ voltages reduce the MOSFET duty cycle. In inverting controllers, the FB_ threshold is 0V, and lower (more negative) FB_ voltages reduce the MOSFET duty cycle.

Auxiliary controllers do not start until the step-up DC-DC output is in regulation. If the step-up, step-down, or any of the auxiliary controllers remains faulted for 100,000

5-Channel Slim DSC Power Supplies

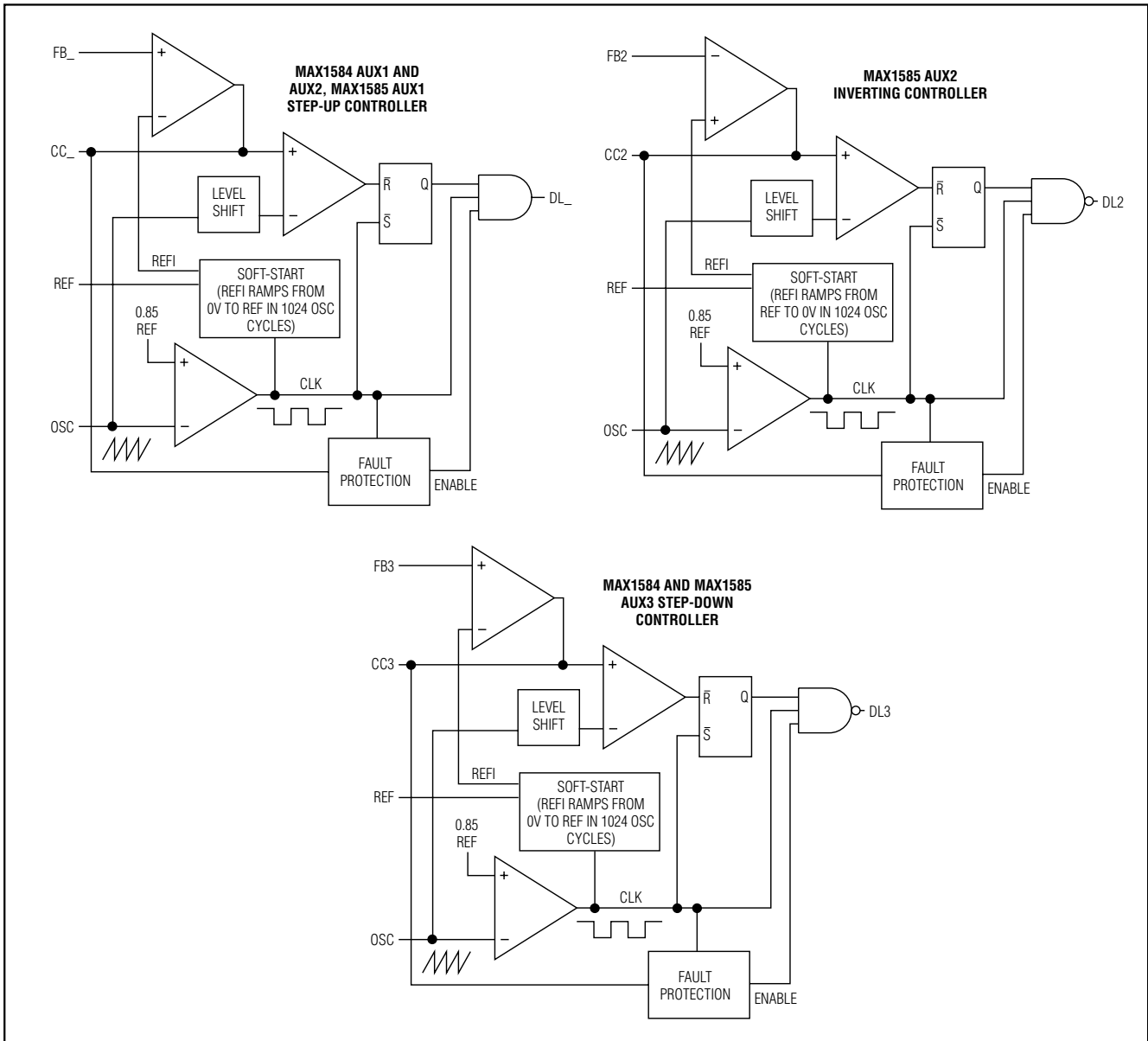

Figure 3. AUX Controller Functional Diagrams

OSC cycles, then all MAX1584/MAX1585 channels latch off.

Maximum Duty Cycle

The MAX1584/MAX1585 auxiliary PWM controllers have a guaranteed maximum duty cycle of 80%. In boost designs that employ continuous current, the maximum duty cycle limits the boost ratio so that:

$$1 - V_{IN} / V_{OUT} \leq 80\%$$

With discontinuous inductor current, no such limit exists for the input/output ratio since the inductor has time to fully discharge before the next cycle begins.

AUX1

AUX1 can be used for conventional DC-DC boost and flyback designs (Figure 5). Its output (DL1) is designed

5-Channel Slim DSC Power Supplies

to drive an N-channel MOSFET. Its feedback (FB1) threshold is 1.25V.

AUX2

In the MAX1584, AUX2 is identical to AUX1.

In the MAX1585, AUX2 is an inverting controller that generates a regulated negative output voltage, typically for CCD and LCD bias. This is handy in height-limited designs where transformers might not be desired.

The AUX2 MOSFET driver (DL2) in the MAX1585 is designed to drive P-channel MOSFETs. DL2 swings from GND to PVSU. See Figure 8 for a typical inverter configuration.

AUX3 DC-DC Step-Down Controller

AUX3 can be used for conventional DC-DC step-down (buck) designs (Figure 1). Its output (DL3) is designed to drive a P-channel MOSFET and swings from GND to PVSU. Its feedback (FB3) threshold is 1.25V.

Master/Slave Configurations

The MAX1584/MAX1585 support the MAX1801 slave PWM controllers that obtain input power, a voltage reference, and an oscillator signal directly from the MAX1584/MAX1585 master. The master/slave configuration allows channels to be easily added and minimizes system cost by eliminating redundant circuitry. The slaves also control the harmonic content of noise since their operating frequency is synchronized to that of the MAX1584/MAX1585 master converter. A MAX1801 connection to the MAX1584/MAX1585 is shown in Figure 12.

Status Outputs (**SDOK**, **AUX1OK**, **SCF**)

The MAX1584/MAX1585 include three versatile status outputs that can provide information to the system. All are open-drain outputs and can directly drive MOSFET switches to facilitate sequencing, disconnect loads during overloads, or perform other hardware-based functions.

SDOK pulls low when the step-down has successfully completed soft-start. **SDOK** goes high impedance in shutdown, overload, and thermal limit. A typical use for **SDOK** is to enable 3.3V power to the CPU I/O after the CPU core is powered up (Figure 13), thus providing safe sequencing in hardware without system intervention.

AUX1OK pulls low when the AUX1 controller has successfully completed soft-start. **AUX1OK** goes high impedance in shutdown, overload, and thermal limit. A typical use for **AUX1OK** is to drive a P-channel MOSFET that gates 5V power to the CCD until the +15V CCD bias (generated by AUX1) is powered up (Figure 14).

SCF goes high (high impedance, open drain) when overload protection occurs. Under normal operation, SCF pulls low. SCF can drive a high-side P-channel MOSFET switch that can disconnect a load during power-up or when a channel turns off in response to a logic command or an overload. Several connections are possible for SCF. One is shown in Figure 15, where SCF provides load disconnect for the step-up on fault and power-up.

Soft-Start

The MAX1584/MAX1585 channels feature a soft-start function that limits inrush current and prevents excessive battery loading at startup by ramping the output voltage of each channel up to the regulation voltage. This is accomplished by ramping the internal reference inputs to each channel error amplifier from 0V to the 1.25V reference voltage over a period of 4096 oscillator cycles (16ms at 500kHz) when initial power is applied or when a channel is enabled. Soft-start is not included in the step-up converter in order to avoid limiting start-up capability with loading.

The step-down soft-start ramp takes half the time (2048 clock cycles) of the other channel ramps. This allows the step-down and AUX3 output (when set to 3.3V) to track each other and rise at nearly the same dV/dt rate on power-up. Once the step-down output reaches its regulation point (1.5V or 1.8V typ), the AUX3 output (3.3V typ) continues to rise at the same ramp rate.

Fault Protection

The MAX1584/MAX1585 have robust fault and overload protection. After power-up, the device is set to detect an out-of-regulation state that could be caused by an overload or short. If any DC-DC converter channel (step-up, step-down, or any of the auxiliary controllers) remains faulted for 100,000 clock cycles (200ms at 500kHz), then **all** outputs latch off until the step-up DC-DC converter is reinitialized by the ONSU pin or by cycling the input power. The fault-detection circuitry for any channel is disabled during its initial turn-on soft-start sequence.

An exception to the standard fault behavior is that there is no 100,000 clock-cycle delay in entering the fault state if the step-up output (PVSU) is dragged below its 2.5V UVLO threshold or is shorted. The step-up UVLO immediately triggers and shuts down all channels. The step-up then continues to attempt to start. If the step-up output short remains, these attempts do not succeed since PVSU remains near ground.

If a soft-short or overload remains on PVSU, the startup oscillator switches the internal N-channel MOSFET, but fault is retrigged if regulation is not achieved by the

5-Channel Slim DSC Power Supplies

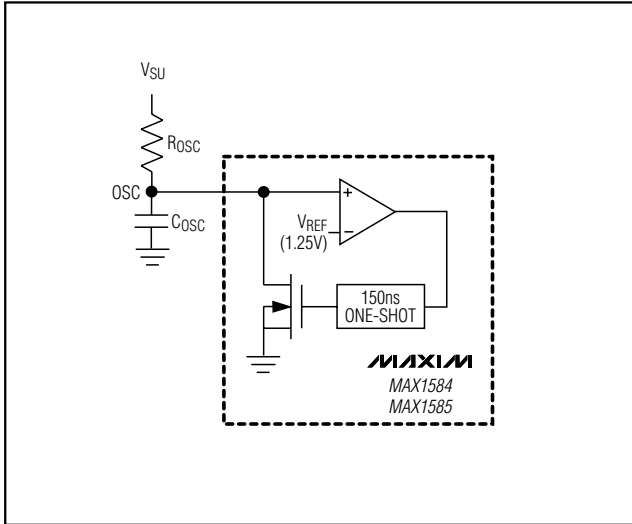

Figure 4. Oscillator Functional Diagram

end of the soft-start interval. If PVSU is dragged below the input, the overload is supplied by the body diode of the internal synchronous rectifier or by a Schottky diode connected from the battery to PVSU. If desired, this overload current can be interrupted by a P-channel MOSFET controlled by SCF, as shown in Figure 15.

Reference

The MAX1584/MAX1585 have internal 1.250V references. Connect a 0.1 μ F ceramic bypass capacitor from REF to GND within 0.2in (5mm) of the REF pin. REF can source up to 200 μ A and is enabled when ONSU is high and PVSU is above 2.5V. The auxiliary controllers and MAX1801 slave controllers (if connected) each sink up to 30 μ A REF current during startup. If the application requires that REF be loaded beyond 200 μ A, buffer REF with a unity-gain amplifier or op amp.

Oscillator

All MAX1584/MAX1585 DC-DC converter channels employ fixed-frequency PWM operation. The operating frequency is set by an RC network at the OSC pin. The range of usable settings is 100kHz to 1MHz. When MAX1801 slave controllers are added, they operate at the frequency set by OSC.

The oscillator uses a comparator, a 150ns one-shot, and an internal NFET switch in conjunction with an external timing resistor and capacitor (Figure 4). When the switch is open, the capacitor voltage exponentially approaches the step-up output voltage from zero with a time constant given by the product of R_{OSC} and C_{OSC} . The comparator output switches high when the capacitor voltage reaches V_{REF} (1.25V). In turn, the one-shot

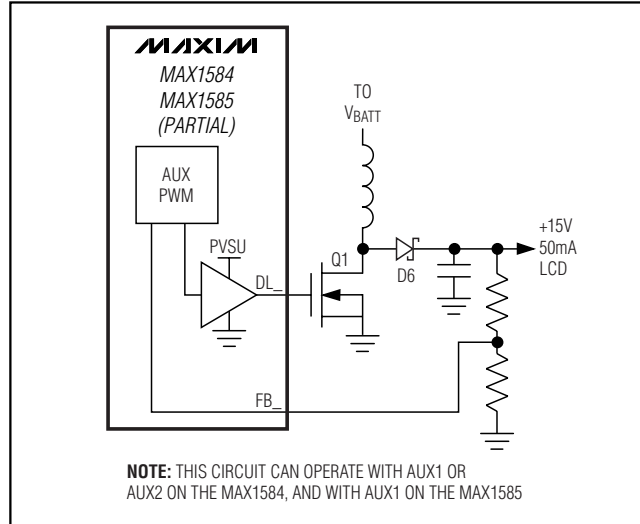

NOTE: THIS CIRCUIT CAN OPERATE WITH AUX1 OR AUX2 ON THE MAX1584, AND WITH AUX1 ON THE MAX1585

Figure 5. +15V LCD Bias with Basic Boost Topology

activates the internal MOSFET switch to discharge the capacitor within a 150ns interval, and the cycle repeats. The oscillation frequency changes as the main output voltage ramps upward following startup. The oscillation frequency is then constant once the main output is in regulation.

Low-Voltage Startup Oscillator

The MAX1584/MAX1585 internal control and reference-voltage circuitry receive power from PVSU and do not function when PVSU is less than 2.5V. To ensure low-voltage startup, the step-up employs a low-voltage startup oscillator that activates at 0.9V if a Schottky rectifier is connected from V_{BATT} to PVSU (1.1V with no Schottky rectifier). The startup oscillator drives the internal N-channel MOSFET at LXSU until PVSU reaches 2.5V, at which point voltage control is passed to the current-mode PWM circuitry.

Once in regulation, the MAX1584/MAX1585 operate with inputs as low as 0.7V since internal power for the IC is supplied by PVSU. At low input voltages, the step-up can have difficulty starting into heavy loads (see the Minimum Startup Voltage vs. Load Current graph in the *Typical Operating Characteristics* section); however, this can be remedied by connecting an external P-channel load switch driven by SCF so the load is not connected until the PVSU is in regulation (Figure 15).

ON_ Control Inputs

The step-up converter activates with a high input at ONSU. The step-down and auxiliary DC-DC converters 1, 2, and 3 activate with a high input at ONSD, ON1, ON2, and ON3, respectively. The step-down and auxil-

5-Channel Slim DSC Power Supplies

ary converters and cannot be activated until PVSU is in regulation. For automatic startup, connect ON_ to PVSU or a logic level greater than 1.6V.

Design Procedure

Setting the Switching Frequency

Choose a switching frequency to optimize external component size or circuit efficiency for the particular application. Typically, switching frequencies between 400kHz and 500kHz offer a good balance between component size and circuit efficiency—higher frequencies generally allow smaller components, and lower frequencies give better conversion efficiency. The switching frequency is set with an external timing resistor (R_{OSC}) and capacitor (C_{OSC}). At the beginning of a cycle, the timing capacitor charges through the resistor until it reaches V_{REF}. The charge time, t₁, is as follows:

$$t_1 = -R_{OSC} \times C_{OSC} \times I_n(1 - 1.25 / V_{PVSU})$$

The capacitor voltage then decays to zero over time t₂ = 150ns. The oscillator frequency is as follows:

$$f_{OSC} = 1 / (t_1 + t_2)$$

f_{OSC} can be set from 100kHz to 1MHz. Choose C_{OSC} between 22pF and 470pF. Determine R_{OSC}:

$$R_{OSC} = (150\text{ns} - 1 / f_{OSC}) / (C_{OSC} \times I_n[1 - 1.25 / V_{PVSU}])$$

See the *Typical Operating Characteristics* section for f_{OSC} vs. R_{OSC} using different values of C_{OSC}.

Setting Output Voltages

The MAX1584/MAX1585 step-up and step-down converters and the AUX1 controllers have resistor-adjustable output voltages. When setting the voltage for all channels except AUX2 on the MAX1585, connect a resistive voltage-divider from the output voltage to the corresponding FB_ input. The FB_ input bias current is less than 100nA, so choose the low-side (FB_-to-GND) resistor (R_L) to be 100kΩ or less. Then calculate the high-side (output-to-FB_) resistor (R_H):

$$R_H = R_L [(V_{OUT} / 1.25) - 1]$$

AUX2 is an inverter on the MAX1585, so the FB2 threshold on the MAX1585 is 0V. To set the MAX1585 AUX2 negative output voltage, connect a resistive voltage-divider from the negative output to the FB2 input, and then to REF. The FB2 input bias current is less than 100nA, so choose the REF-side (FB2-to-REF) resistor (R_{REF}) to be 100kΩ or less. Then calculate the top-side (negative output-to-FB2) resistor:

$$R_{TOP} = R_{REF} (-V_{OUT(AUX2)} / 1.25)$$

General Filter-Capacitor Selection

The input capacitor in a DC-DC converter reduces current peaks drawn from the battery or other input power source and reduces switching noise in the controller. The impedance of the input capacitor at the switching frequency should be less than that of the input source so high-frequency switching currents do not pass through the input source.

The output capacitor keeps output ripple small and ensures control-loop stability. The output capacitor must also have low impedance at the switching frequency. Ceramic, polymer, and tantalum capacitors are suitable, with ceramic exhibiting the lowest ESR and high-frequency impedance.

Output ripple with a ceramic output capacitor is approximately:

$$V_{RIPPLE} = I_L(\text{PEAK}) [1 / (2\pi \times f_{OSC} \times C_{OUT})]$$

If the capacitor has significant ESR, the output ripple component due to capacitor ESR is:

$$V_{RIPPLE(ESR)} = I_L(\text{PEAK}) \times \text{ESR}$$

Output capacitor specifics are also discussed in each converter's *Compensation* section.

Step-Up Component Selection

The external components required for the step-up are an inductor, an input and output filter capacitor, and a compensation RC.

The inductor is typically selected to operate with continuous current for best efficiency. An exception might be if the step-up ratio, (V_{OUT} / V_{IN}), is greater than 1 / (1 - D_{MAX}), where D_{MAX} is the maximum PWM duty factor of 80%.

When using the step-up channel to boost from a low input voltage, loaded startup is aided by connecting a Schottky diode from the battery to PVSU. See the Minimum Startup Voltage vs. Load Current graph in the *Typical Operating Characteristics* section.

Step-Up Inductor

In most step-up designs, a reasonable inductor value (L_{IDEAL}) can be derived from the following equation, which sets continuous peak-to-peak inductor current at half the DC inductor current:

$$L_{IDEAL} = [2V_{IN(\text{MAX})} \times D(1 - D)] / (I_{OUT} \times f_{OSC})$$

where D is the duty factor given by:

$$D = 1 - (V_{IN} / V_{OUT})$$

Given L_{IDEAL}, the consistent peak-to-peak inductor current is 0.5 × I_{OUT} / (1 - D). The peak inductor current is as follows:

5-Channel Slim DSC Power Supplies

$$I_{IND(PK)} = 1.25 \times I_{OUT} / (1 - D)$$

Inductance values smaller than L_{IDEAL} can be used to reduce inductor size; however, if much smaller values are used, inductor current rises and a larger output capacitance might be required to suppress output ripple.

Step-Up Compensation

The inductor and output capacitor are usually chosen first in consideration of performance, size, and cost. The compensation resistor and capacitor are then chosen to optimize control-loop stability. In some cases, it helps to readjust the inductor or output capacitor value to get optimum results. For typical designs, the component values in the circuit of Figure 1 yield good results.

The step-up converter employs current-mode control, thereby simplifying the control-loop compensation. When the converter operates with continuous inductor current (typically the case), a right-half-plane zero appears in the loop-gain frequency response. To ensure stability, the control-loop gain should cross over (drop below unity gain) at a frequency (f_C) much less than that of the right-half-plane zero.

The relevant characteristics for step-up channel compensation are as follows:

- Transconductance (from FBSU to CCSU), g_{MEA} (135 μ S)
- Current-sense amplifier transresistance, R_{CS} (0.3V/A)
- Feedback regulation voltage, V_{FB} (1.25V)
- Step-up output voltage, V_{SU} , in V
- Output load equivalent resistance, R_{LOAD} , in $\Omega = V_{SUOUT} / I_{LOAD}$

The key steps for step-up compensation are as follows:

- 1) Place f_C sufficiently below the right-half-plane zero (RHPZ) and calculate C_C .
- 2) Select R_C based on the allowed load-step transient. R_C sets a voltage delta on the C_C pin that corresponds to load-current step.
- 3) Calculate the output-filter capacitor (C_{OUT}) required to allow the R_C and C_C selected.
- 4) Determine if C_P is required (if calculated to be $>10pF$).

For continuous conduction, the right-half-plane zero frequency (f_{RHPZ}) is given by the following:

$$f_{RHPZ} = V_{SUOUT} (1 - D)^2 / (2\pi \times L \times I_{LOAD})$$

where D = the duty cycle = $1 - (V_{IN} / V_{OUT})$, L is the inductor value, and I_{LOAD} is the maximum output current. Typically, target crossover (f_C) for 1/6 of the RHPZ. For example, if we assume $f_{OSC} = 500kHz$, $V_{IN} = 2.5V$, $V_{OUT} = 5V$, and $I_{OUT} = 0.5A$, then $R_{LOAD} = 10\Omega$. If we select $L = 4.7\mu H$, then:

$$f_{RHPZ} = 5 (2.5 / 5)^2 / (2\pi \times 4.7 \times 10^{-6} \times 0.5) = 84.65kHz$$

Choose $f_C = 14kHz$. Calculate C_C :

$$\begin{aligned} C_C &= (V_{FB} / V_{OUT})(R_{LOAD} / R_{CS})(g_M / 2\pi \times f_C)(1 - D) \\ &= (1.25 / 5)(10 / 0.3) \times (135\mu S / (6.28 \times 14kHz)) (2/5) \\ &= 6.4nF \end{aligned}$$

Choose 6.8nF.

Now select R_C so transient-droop requirements are met. As an example, if 4% transient droop is allowed, the input to the error amplifier moves $0.04 \times 1.25V$, or 50mV. The error-amp output drives $50mV \times 135\mu S$, or 6.75 μA across R_C to provide transient gain. Since the current-sense transresistance is 0.3V/A, the value of R_C that allows the required load step swing is as follows:

$$R_C = 0.3 I_{IND(PK)} / 6.75\mu A$$

In a step-up DC-DC converter, if L_{IDEAL} is used, output current relates to inductor current by:

$$I_{IND(PK)} = 1.25 \times I_{OUT} / (1 - D) = 1.25 \times I_{OUT} \times V_{OUT} / V_{IN}$$

So for a 500mA output load step with $V_{IN} = 2.5V$ and $V_{OUT} = 5V$:

$$R_C = [1.25(0.3 \times 0.5 \times 5) / 2] / 6.75\mu A = 69.4k\Omega$$

Note that the inductor does not limit the response in this case since it can ramp at $2.5V / 4.7\mu H$, or 530mA/ μs .

The output filter capacitor is then chosen so the C_{OUT} R_{LOAD} pole cancels the R_C C_C zero:

$$C_{OUT} \times R_{LOAD} = R_C \times C_C$$

For the example:

$$C_{OUT} = 68k\Omega \times 6.8nF / 10\Omega = 46\mu F$$

Choose 47 μF for C_{OUT} . If the available C_{OUT} is substantially different from the calculated value, insert the available C_{OUT} value into the above equation and recalculate R_C . Higher substituted C_{OUT} values allow a higher R_C , which provides higher transient gain and consequently less transient droop.

If the output filter capacitor has significant ESR, a zero occurs at the following:

$$Z_{ESR} = 1 / (2\pi \times C_{OUT} \times R_{ESR})$$

5-Channel Slim DSC Power Supplies

If $Z_{ESR} > f_C$, it can be ignored, as is typically the case with ceramic output capacitors. If Z_{ESR} is less than f_C , it should be cancelled with a pole set by capacitor C_P connected from CCSU to GND:

$$C_P = C_{OUT} \times R_{ESR} / R_C$$

If C_P is calculated to be $< 10\text{pF}$, it can be omitted.

Step-Down Component Selection

Step-Down Inductor

The external components required for the step-down are an inductor, input and output filter capacitors, and a compensation RC network.

The MAX1585/1585 step-down converter provides best efficiency with continuous inductor current. A reasonable inductor value (L_{IDEAL}) can be derived from the following:

$$L_{IDEAL} = [2(V_{IN}) \times D(1 - D)] / I_{OUT} \times f_{OSC}$$

which sets the peak-to-peak inductor current at half the DC inductor current. D is the duty cycle:

$$D = V_{OUT} / V_{IN}$$

Given L_{IDEAL} , the peak-to-peak inductor current is $0.5 \times I_{OUT}$. The absolute peak inductor current is $1.25 \times I_{OUT}$. Inductance values smaller than L_{IDEAL} can be used to reduce inductor size; however, if much smaller values are used, inductor current rises and a larger output capacitance may be required to suppress output ripple. Larger values than L_{IDEAL} can be used to obtain higher output current, but with typically larger inductor size.

Step-Down Compensation

The relevant characteristics for step-down compensation are as follows:

- Transconductance (from FBSD to CCSD), g_{MEA} ($135\mu\text{S}$)
- Current-sense amplifier transresistance, R_{CS} (0.6V/A)
- Feedback regulation voltage, V_{FB} (1.25V)
- Step-down output voltage, V_{SD} , in V
- Output load equivalent resistance, R_{LOAD} , in $\Omega = V_{SD} / I_{LOAD}$

The key steps for step-down compensation are as follows:

- 1) Set the compensation RC zero to cancel the R_{LOAD} C_{OUT} pole.
- 2) Set the loop crossover below 1/10 the switching frequency.

If we assume $V_{IN} = 3.5\text{V}$, $V_{OUT} = 1.5\text{V}$, and $I_{OUT} = 250\text{mA}$, then $R_{LOAD} = 6\Omega$.

If we select $f_{OSC} = 500\text{kHz}$ and $L = 22\mu\text{H}$,

choose $f_C = 24\text{kHz}$ and calculate C_C :

$$\begin{aligned} C_C &= (V_{FB} / V_{OUT})(R_{LOAD} / R_{CS})(g_M / 2\pi \times f_C) \\ &= (1.25 / 1.5)(6 / 0.6) \times (135\mu\text{S} / (6.28 \times 40\text{kHz})) \\ &= 4.5\text{nF} \end{aligned}$$

Choose 4.7nF .

Now select R_C so transient-droop requirements are met. For example, if 4% transient droop is allowed, the input to the error amplifier moves $0.04 \times 1.25\text{V}$, or 50mV . The error-amp output drives $50\text{mV} \times 135\mu\text{S}$, or $6.75\mu\text{A}$ across R_C to provide transient gain. Since the current-sense transresistance is 0.6V/A , the value of R_C that allows the required load step swing is as follows:

$$R_C = 0.6 \times I_{IND(PK)} / 6.75\mu\text{A}$$

In a step-down DC-DC converter, if L_{IDEAL} is used, output current relates to inductor current by the following:

$$I_{IND(PK)} = 1.25 \times I_{OUT}$$

So for a 250mA output load step with $V_{IN} = 3.5\text{V}$ and $V_{OUT} = 1.5\text{V}$:

$$R_C = (1.25 \times 0.6 \times 0.25) / 6.75\mu\text{A} = 27.8\text{k}\Omega$$

Choose $27\text{k}\Omega$.

The inductor does somewhat limit the response in this case since it ramps at $(V_{IN} - V_{OUT}) / 22\mu\text{H}$, or $(3.5 - 1.5) / 22\mu\text{H} = 90\text{mA}/\mu\text{s}$.

The output filter capacitor is then chosen so the C_{OUT} R_{LOAD} pole cancels the R_C C_C zero:

$$C_{OUT} \times R_{LOAD} = R_C \times C_C$$

For the example:

$$C_{OUT} = 27\text{k}\Omega \times 4.7\text{nF} / 6\Omega = 21\mu\text{F}$$

Choose $22\mu\text{F}$ or greater.

If the output filter capacitor has significant ESR, a zero occurs at:

$$Z_{ESR} = 1 / (2\pi \times C_{OUT} \times R_{ESR})$$

If $Z_{ESR} > f_C$, it can be ignored, as is typically the case with ceramic output capacitors. If Z_{ESR} is less than f_C , it should be cancelled with a pole set by capacitor C_P connected from CCSD to GND:

$$C_P = C_{OUT} \times R_{ESR} / R_C$$

If C_P is calculated to be $< 10\text{pF}$, it can be omitted.

AUX Controller Component Selection

External MOSFET

MAX1584/MAX1585 AUX1(step-up) controllers drive external logic-level N-channel MOSFETs. AUX3 (step-down) controllers drive P-channel MOSFETs. AUX2 (step-up) on the MAX1584 drives an N channel, while AUX2 (inverting) on the MAX1585 drives a P channel.

5-Channel Slim DSC Power Supplies

Significant MOSFET selection parameters are as follows:

- On-resistance ($R_{DS(ON)}$)
- Maximum drain-to-source voltage ($V_{DS(MAX)}$)
- Total gate charge (Q_G)
- Reverse transfer capacitance (C_{RSS})

DL1 and DL3 swing between PVSU and GND. DL2 swings between INDL2 and GND. Use a MOSFET with on-resistance specified at or below the DL_{-} drive voltage. The gate charge, Q_G , includes all capacitance associated with charging the gate and helps to predict MOSFET transition time between on and off states. MOSFET power dissipation is a combination of on-resistance and transition losses. The on-resistance loss is as follows:

$$P_{RDS(ON)} = D \times I_L^2 \times R_{DS(ON)}$$

where D is the duty cycle, I_L is the average inductor current, and $R_{DS(ON)}$ is the MOSFET on-resistance. The transition loss is approximately:

$$P_{TRANS} = (V_{OUT} \times I_L \times f_{OSC} \times t_T) / 3$$

where V_{OUT} is the output voltage, I_L is the average inductor current, f_{OSC} is the switching frequency, and t_T is the transition time. The transition time is approximately Q_G / I_G , where Q_G is the total gate charge, and I_G is the gate-drive current (0.5A typ). The total power dissipation in the MOSFET is as follows:

$$P_{MOSFET} = P_{RDS(ON)} + P_{TRANS}$$

Diode

For most AUX applications, a Schottky diode rectifies the output voltage. Schottky low forward voltage and fast recovery time provide the best performance in most applications. Silicon signal diodes (such as 1N4148) are sometimes adequate in low-current (<10mA), high-voltage (>10V) output circuits where the output voltage is large compared to the diode forward voltage.

AUX Compensation

The auxiliary controllers employ voltage-mode control to regulate their output voltage. Optimum compensation depends on whether the design uses continuous or discontinuous inductor current.

AUX Step-Up, Discontinuous Inductor Current

When the inductor current falls to zero on each switching cycle, it is described as *discontinuous*. The inductor is not utilized as efficiently as with continuous current, but in light-load applications, this often has little negative impact since the coil losses may already be low compared to other losses. A benefit of discontinuous

inductor current is more flexible loop compensation, and no maximum duty-cycle restriction on boost ratio.

To ensure discontinuous operation, the inductor must have a sufficiently low inductance to fully discharge on each cycle. This occurs when:

$$L < [V_{IN}^2 (V_{OUT} - V_{IN}) / V_{OUT}^3] [R_{LOAD} / (2f_{OSC})]$$

A discontinuous current boost has a single pole at the following:

$$f_P = (2V_{OUT} - V_{IN}) / (2\pi \times R_{LOAD} \times C_{OUT} \times V_{OUT})$$

Choose the integrator cap so the unity-gain crossover, f_C , occurs at $f_{OSC} / 10$ or lower. For many AUX circuits, such as those powering motors, LEDs, or other loads that do not require fast transient response, it is often acceptable to overcompensate by setting f_C at $f_{OSC} / 20$ or lower.

C_C is then determined by the following:

$$C_C = [2V_{OUT} \times V_{IN} / ((2V_{OUT} - V_{IN}) \times V_{RAMP})] [V_{OUT} / (K(V_{OUT} - V_{IN}))]^{1/2} [(V_{FB} / V_{OUT})(g_M / (2\pi \times f_C))]$$

where:

$$K = 2L \times f_{OSC} / R_{LOAD}$$

and V_{RAMP} is the internal voltage ramp of 1.25V.

The C_C R_C zero is then used to cancel the f_P pole, so:

$$R_C = R_{LOAD} \times C_{OUT} \times V_{OUT} / [(2V_{OUT} - V_{IN}) \times C_C]$$

AUX Step-Up, Continuous Inductor Current

Continuous inductor current can sometimes improve boost efficiency by lowering the ratio between peak inductor current and output current. It does this at the expense of a larger inductance value that requires larger size for a given current rating. With continuous inductor-current boost operation, there is a right-half-plane zero, Z_{RHP} , at the following:

$$Z_{RHP} = (1 - D)^2 R_{LOAD} / (2\pi \times L)$$

where $(1 - D) = V_{IN} / V_{OUT}$ (in a boost converter)

There is a complex pole pair at the following:

$$f_0 = V_{OUT} / [2\pi \times V_{IN} (L \times C_{OUT})^{1/2}]$$

If the zero due to the output capacitor capacitance and ESR is less than 1/10 the right-half-plane zero:

$$Z_{COUT} = 1 / (2\pi \times C_{OUT} \times R_{ESR}) < Z_{RHP} / 10$$

Then choose C_C so the crossover frequency f_C occurs at Z_{COUT} . The ESR zero provides a phase boost at crossover:

$$C_C = (V_{IN} / V_{RAMP})(V_{FB} / V_{OUT})(g_M / (2\pi \times Z_{COUT}))$$

Choose R_C to place the integrator zero, $1 / (2\pi \times R_C \times C_C)$, at f_0 to cancel one of the pole pairs:

$$R_C = V_{IN} (L \times C_{OUT})^{1/2} / (V_{OUT} \times C_C)$$

5-Channel Slim DSC Power Supplies

If Z_{COUT} is not less than $Z_{RHP} / 10$ (as is typical with ceramic output capacitors) and continuous conduction is required, then cross the loop over before Z_{RHP} and f_0 :

$$f_c < f_{OSC} / 10, \text{ and } f_c < Z_{RHP} / 10$$

In that case:

$$C_C = (V_{IN} / V_{RAMP})(V_{FB} / V_{OUT})(g_M / (2\pi \times f_c))$$

Place:

$$1 / (2\pi \times R_C \times C_C) = 1 / (2\pi \times R_{LOAD} \times C_{OUT}), \text{ so that } R_C = R_{LOAD} \times C_{OUT} / C_C$$

Or, reduce the inductor value for discontinuous operation.

AUX3 Step-Down Compensation

It is expected that most AUX3 step-down applications employ continuous inductor current to optimize inductor size and efficiency. To ensure stability, the control-loop gain should cross over (drop below unity gain) at a frequency (f_c) much less than that of the switching frequency.

The relevant characteristics for voltage-mode step-down compensation are as follows:

- Transconductance (from FB3 to CC3), g_{MEA} (135 μ S)
- Oscillator ramp voltage, V_{RAMP} (1.25V)
- Feedback regulation voltage, V_{FB} (1.25V)
- Output voltage, V_{OUT3} , in V
- Output load equivalent resistance, R_{LOAD} , in $\Omega = V_{OUT3} / I_{LOAD}$
- Characteristic impedance of the LC output filter, $R_O = (L / C)^{1/2}$

The key steps for AUX3 step-down compensation are as follows:

- 1) Place f_c sufficiently below the switching frequency ($f_{OSC} / 10$).
- 2) Calculate C_{OUT} .
- 3) Calculate the complex pole pair due to the output LC filter.
- 4) Add two zeros to cancel the complex pole pair.
- 5) Add two high-frequency poles to optimize gain and phase margin.

If we assume $V_{IN} = 5V$, $V_{OUT} = 3.3V$, and $I_{OUT} = 300mA$, then $R_{LOAD} = 11\Omega$. If we select $f_{OSC} = 500kHz$ and $L = 10\mu H$, select the crossover frequency to be 1/10 the OSC frequency:

$$f_c = f_{OSC} / 10 = 50kHz$$

For 3.3V output, select $R_{14} = 30.1k\Omega$ and $R_{15} = 18.2k\Omega$. See the *Setting Output Voltages* section.

Calculate the equivalent impedance, R_{EQ} :

$$R_{EQ} = R_{SOURCE} + R_L + ESR + R_{DS(ON)}$$

where R_{SOURCE} is the output impedance of the source (this is the output impedance of the step-up converter when the AUX3 step-down is powered from the step-up), R_L is the inductor DC resistance, ESR is the filter-capacitor equivalent resistance, and $R_{DS(ON)}$ is the on-resistance of the external MOSFET.

The output impedance of the step-up converter (R_{SOURCE}) is approximately 1Ω at f_0 . Since the sum of $R_L + ESR + R_{DS(ON)}$ is small compared to 1Ω , assume $R_{EQ} = 1\Omega$. Choose C_{OUT} so R_O is less than $R_{EQ} / 2$:

$$C_{OUT} > L / [(R_{EQ} / 2)^2] = 10\mu H / 0.25 = 40\mu F$$

Choose $C_{OUT} = 47\mu F$:

$$C_4 = (V_{IN} / V_{RAMP})(1 / [2\pi \times R_{14} \times f_c]) = (5 / 1.25)(1 / [2\pi \times 30.1k \times 50kHz]) = 423pF$$

Choose $C_4 = 470pF$.

Cancel one pole of the complex pole pair by placing the $R_4 C_4$ zero at $0.75 f_0$. The complex pole pair is at the following:

$$f_0 = 1 / [2\pi(L \times C_{OUT})^{1/2}] = 1 / [2\pi(10\mu H \times 47\mu F)^{1/2}] = 7.345kHz$$

Choose $R_4 = 1 / (2\pi \times C_4 \times 0.75 \times f_0)$

$$= 1 / (2\pi \times 470pF \times 0.75 \times 7.345kHz) = z$$

Choose $R_4 = 61.9k\Omega$ (standard 1% value). Ensure that $R_4 > 2 / g_{MEA} = 14.8k\Omega$. If it is not greater, reselect R_{14} and R_{15} .

Cancel the second pole of the complex pole pair by placing the $R_{14} C_{20}$ zero at $1.25 \times f_0$.

$$C_{20} = 1 / (2\pi \times R_{14} \times 1.25 \times f_0) = 1 / (2\pi \times 30.1k \times 1.25 \times 7.345kHz) = 576pF$$

Choose $C_{20} = 560pF$.

Roll off the gain below the switching frequency by placing a pole at $f_{OSC} / 2$:

$$R_{22} = 1 / (2\pi \times C_{20} [f_{OSC} / 2]) = 1 / (2\pi \times 560pF \times 250kHz) = 1.137k\Omega$$

Choose $R_{22} = 1.2k\Omega$.

If the output filter capacitor has significant ESR, a zero occurs at the following:

$$Z_{ESR} = 1 / (2\pi \times C_{OUT} \times RESR)$$

Use the $R_4 C_{22}$ pole to cancel the ESR zero:

$$C_{22} = C_{OUT} \times RESR / R_4$$

If C_{22} is calculated to be $< 10pF$, it can be omitted.

5-Channel Slim DSC Power Supplies

MAX1585 AUX2 Inverter Compensation, Discontinuous Inductor Current

If the load current is very low (40mA or less), discontinuous current is preferred for simple loop compensation and freedom from duty-cycle restrictions on the inverter input-output ratio. To ensure discontinuous operation, the inductor must have a sufficiently low inductance to fully discharge on each cycle. This occurs when:

$$L < [V_{IN} / (|V_{OUT}| + V_{IN})]^2 R_{LOAD} / (2f_{OSC})$$

A discontinuous current inverter has a single pole at:

$$f_p = 2 / (2\pi \times R_{LOAD} \times C_{OUT})$$

Choose the integrator cap so the unity-gain crossover, f_c , occurs at $f_{OSC} / 10$ or lower. Note that for many AUX circuits that do not require fast transient response, it is often acceptable to overcompensate by setting f_c at $f_{OSC} / 20$ or lower.

C_C is then determined by the following:

$$C_C = [V_{IN} / (K^{1/2} \times V_{RAMP})][V_{REF} / (V_{OUT} + V_{REF})] [g_m / (2\pi \times f_c)]$$

where:

$K = 2L \times f_{OSC} / R_{LOAD}$, and V_{RAMP} is the internal voltage ramp of 1.25V.

The C_C R_C zero then is used to cancel the f_p pole, so:

$$R_C = (R_{LOAD} \times C_{OUT}) / (2 C_C)$$

MAX1585 AUX2 Inverter Compensation, Continuous Inductor Current

Continuous inductor current may be more suitable for larger load currents (50mA or more). It improves efficiency by lowering the ratio between peak inductor current and output current. It does this at the expense of a larger inductance value that requires larger size for a given current rating. With continuous inductor-current inverter operation, there is a right-half-plane zero, Z_{RHP} , at:

$$Z_{RHP} = [(1 - D)^2 / D] \times R_{LOAD} / (2\pi \times L)$$

where $D = |V_{OUT}| / (|V_{OUT}| + V_{IN})$ (in an inverter).

There is a complex pole pair at:

$$f_0 = (1 - D) / (2\pi(L \times C)^{1/2})$$

If the zero due to the output-capacitor capacitance and ESR is less than 1/10 the right-half-plane zero:

$$Z_{COUT} = 1 / (2\pi \times C_{OUT} \times R_{ESR}) < Z_{RHP} / 10$$

Then choose C_C so the crossover frequency, f_c , occurs at Z_{COUT} . The ESR zero provides a phase boost at crossover.

$$C_C = (V_{IN} / V_{RAMP})[V_{REF} / (V_{REF} + |V_{OUT}|)][g_m / (2\pi \times Z_{COUT})]$$

Choose R_C to place the integrator zero, $1 / (2\pi \times R_C \times C_C)$, at f_0 to cancel one of the pole pairs:

$$R_C = (L \times C_{OUT})^{1/2} / [(1 - D) \times C_C]$$

If Z_{COUT} is not less than $Z_{RHP} / 10$ (as is typical with ceramic output capacitors) and continuous conduction is required, then cross the loop over before Z_{RHP} and f_0 :

$$f_c < f_0 / 10, \text{ and } f_c < Z_{RHP} / 10$$

In that case:

$$C_C = (V_{IN} / V_{RAMP})[V_{REF} / (V_{REF} + |V_{OUT}|)][g_m / (2\pi \times f_c)]$$

Place:

$$1 / (2\pi \times R_C \times C_C) = 1 / (2\pi \times R_{LOAD} \times C_{OUT}), \text{ so that}$$

$$R_C = R_{LOAD} \times C_{OUT} / C_C$$

Or, reduce the inductor value for discontinuous operation.

Applications Information

LED, LCD, and Other Boost Applications

Any AUX channel can be used for a wide variety of step-up applications. These include generating 5V or some other voltage for motor or actuator drive, generating 15V or a similar voltage for LCD bias, or generating a step-up current source to efficiently drive a series array of white LEDs to display backlighting. Figures 5 and 6 show examples of these applications.

Multiple-Output Flyback Circuits

Some applications require multiple voltages from a single converter channel. This is often the case when generating voltages for CCD bias or LCD power. Figure 7 shows a two-output flyback configuration with AUX_. The controller drives an external MOSFET that switches the transformer primary. Two transformer secondaries generate the output voltages. Only one positive output voltage can be fed back, so the other voltages are set by the turns ratio of the transformer secondaries. The load stability of the other secondary voltages depends on transformer leakage, inductance, and winding resistance. Voltage regulation is best when the load on the secondary that is not fed back is small compared to the load on the one that is fed back. Regulation also improves if the load current range is limited. Consult the transformer manufacturer for the proper design for a given application.

5-Channel Slim DSC Power Supplies

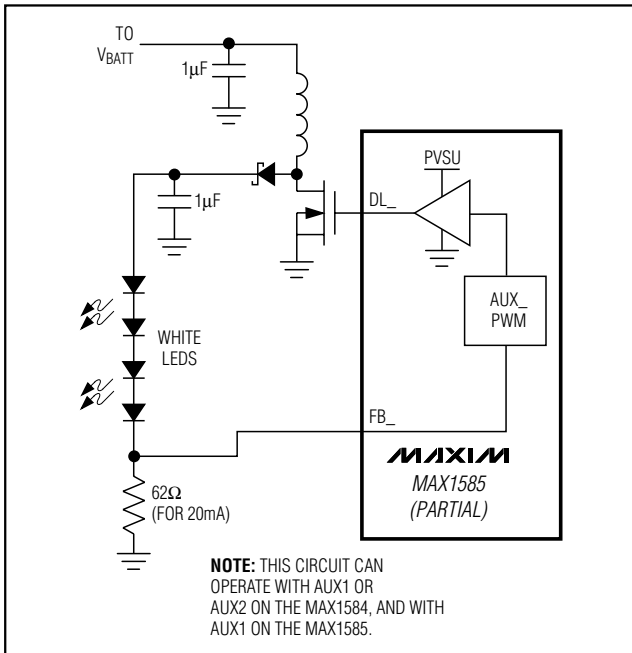

Figure 6. AUX Channel Powering a White LED Step-Up Current Source

Transformerless Inverter for Negative CCD Bias (AUX2, MAX1585)

On the MAX1585, AUX2 is set up to drive an external P-channel MOSFET in an inverting configuration. DL2 drives low to turn on the MOSFET, and FB2 has inverted polarity and a 0V threshold. This is useful for generating negative CCD bias without a transformer, particularly with high pixel-count cameras that have a greater negative CCD load current. Figures 1 and 8 show such a configuration for the MAX1585.

Boost with Charge Pump for Positive and Negative Outputs

Another method of producing bipolar output voltages without a transformer is with an AUX controller and a charge-pump circuit as shown in Figure 9. When MOSFET Q1 turns off, the voltage at its drain rises to supply current to V_{OUT+} . At the same time, C1 charges to the voltage V_{OUT+} through D1. When the MOSFET turns on, C1 discharges through D3, thereby charging C3 to V_{OUT-} minus the drop across D3 to create roughly the same voltage as V_{OUT+} at V_{OUT-} , but with inverted polarity.

If different magnitudes are required for the positive and negative voltages, a linear regulator can be used at one of the outputs to achieve the desired voltages. One such

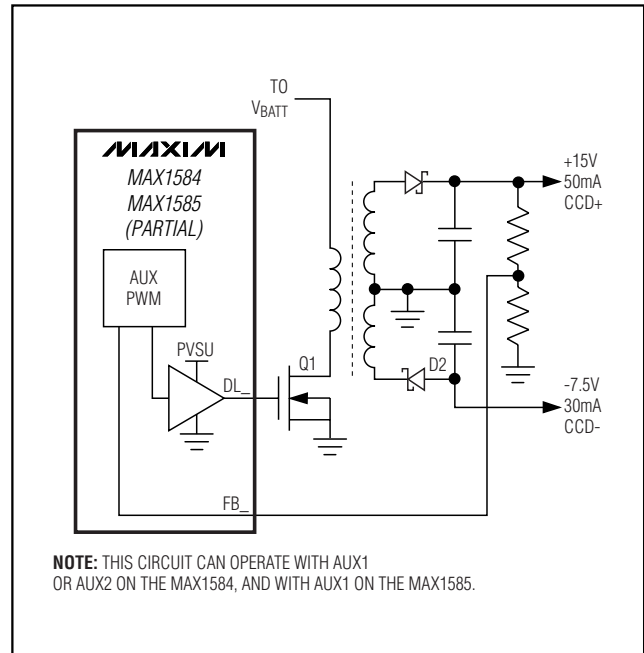

Figure 7. +15V and -7.5V CCD Bias with Transformer

connection is shown in Figure 10. This circuit is somewhat unique in that a **positive-output** linear regulator is able to regulate a negative voltage output. It does this by controlling the charge current flowing to the flying capacitor rather than directly regulating at the output.

SEPIC Boost-Buck

The MAX1584/MAX1585s' internal switch step-up and step-down can be cascaded to make a high-efficiency boost-buck converter, but it is sometimes desirable to build a second boost-buck converter with an AUX controller.

One type of step-up/step-down converter is the SEPIC, shown in Figure 11. Inductors L1 and L2 can be separate inductors or can be wound on a single core and coupled like a transformer. Typically, a coupled inductor improves efficiency since some power is transferred through the coupling so less power passes through the coupling capacitor (C2). Likewise, C2 should have low ESR to improve efficiency. The ripple-current rating must be greater than the larger of the input and output currents. The MOSFET (Q1) drain-source voltage rating and the rectifier (D1) reverse-voltage rating must exceed the sum of the input and output voltages. Other types of step-up/step-down circuits are a flyback converter and a step-up converter followed by a linear regulator.

5-Channel Slim DSC Power Supplies

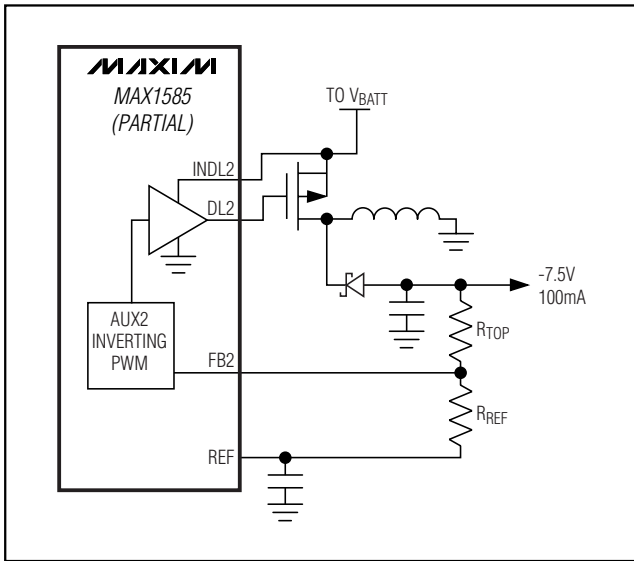
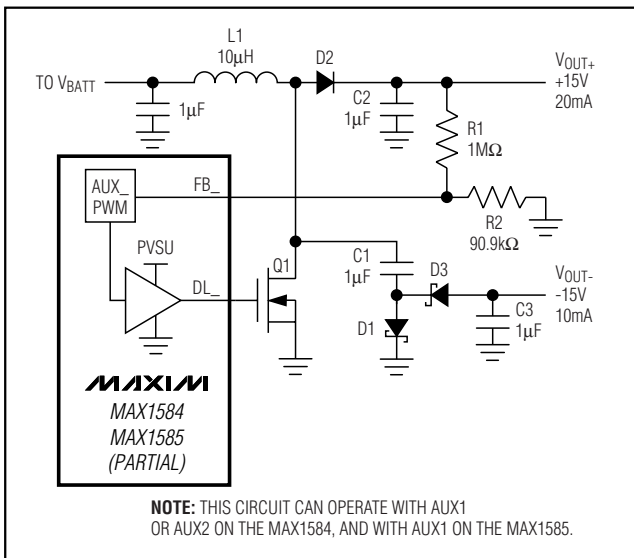

Figure 8. Regulated -7.5V Negative CCD Bias Provided by Conventional Inverter (MAX1585 Only)



NOTE: THIS CIRCUIT CAN OPERATE WITH AUX1 OR AUX2 ON THE MAX1584, AND WITH AUX1 ON THE MAX1585.

Figure 9. ±15V Output from AUX-Driven Boost with Charge-Pump Inversion

Adding a MAX1801 Slave

The MAX1801 is a 6-pin SOT slave DC-DC controller that can be connected to generate additional output voltages. It does not generate its own reference or oscillator. Instead, it uses the reference and oscillator of the MAX1584/MAX1585 (Figure 12).

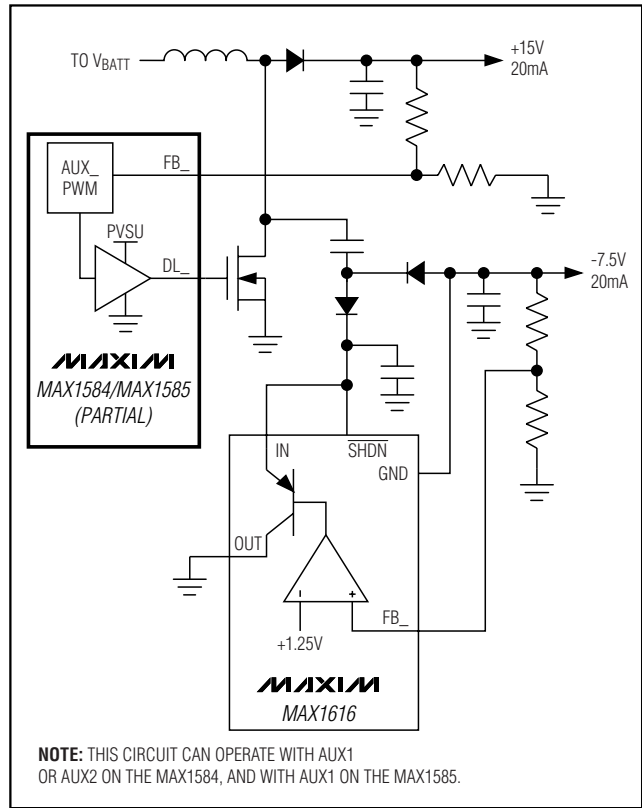

NOTE: THIS CIRCUIT CAN OPERATE WITH AUX1 OR AUX2 ON THE MAX1584, AND WITH AUX1 ON THE MAX1585.

Figure 10. +15V and -7.5V CCD Bias Without Transformer from AUX-Driven Boost and Charge Pump. A positive linear regulator (MAX1616) regulates the negative output of the charge pump.

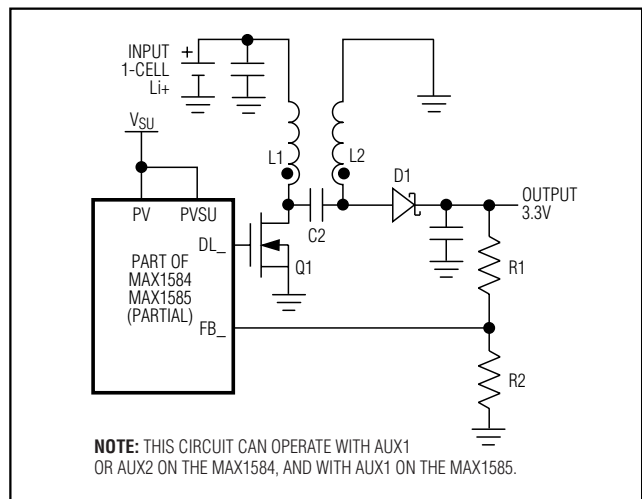

NOTE: THIS CIRCUIT CAN OPERATE WITH AUX1 OR AUX2 ON THE MAX1584, AND WITH AUX1 ON THE MAX1585.

Figure 11. SEPIC Converter for Additional Boost-Buck Channel

5-Channel Slim DSC Power Supplies

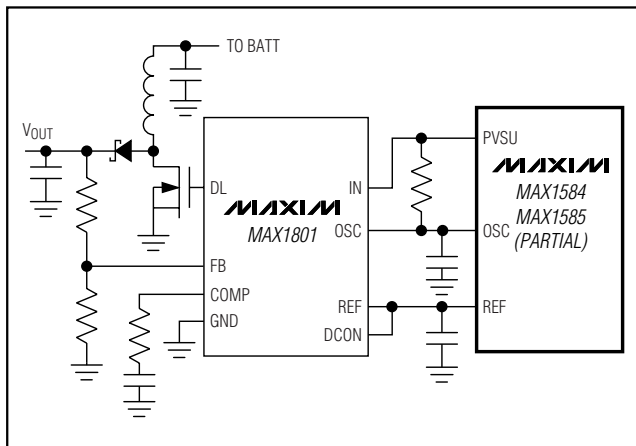

Figure 12. Adding a PWM Channel with an External MAX1801 Slave Controller

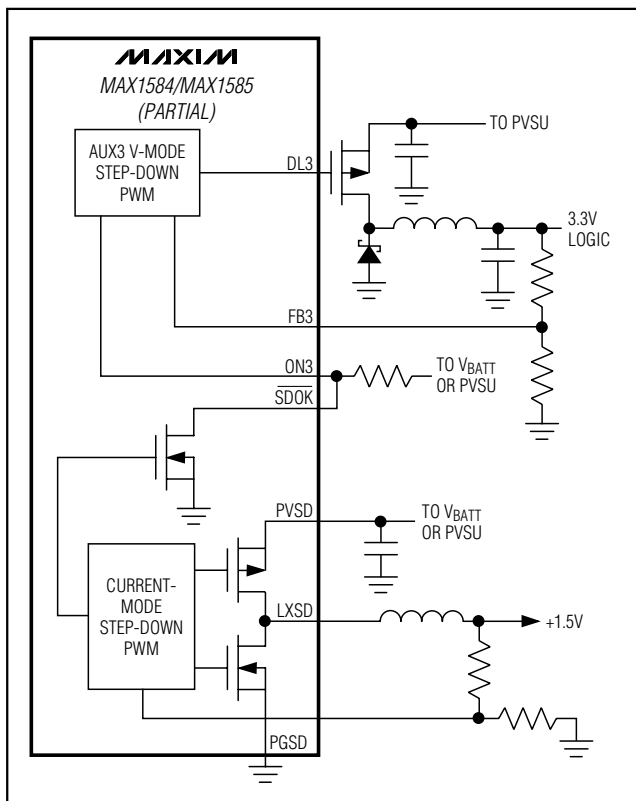

Figure 13. Using \overline{SDOK} to Gate 3.3V Power to CPU After the Core Voltage Is in Regulation

The MAX1801 controller operation and design are similar to that of the MAX1584/MAX1585 AUX controllers. All comments in the *AUX Controller Component*

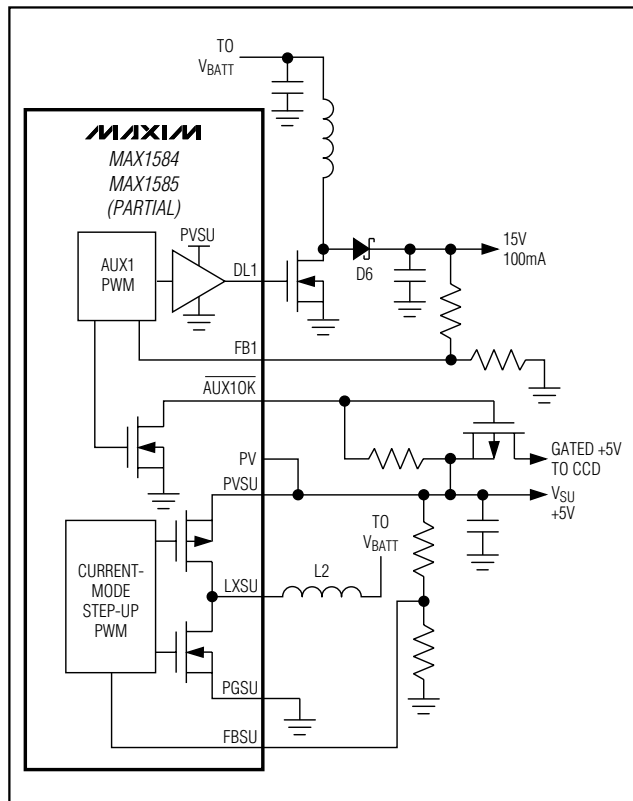

Figure 14. $\overline{AUX10K}$ drives an external PFET that switches 5V to the CCD only after the +15V CCD bias supply is in regulation.

Selection section also apply to add-on MAX1801 slave controllers. For more details, refer to the MAX1801 data sheet.

Using \overline{SDOK} and $\overline{AUX10K}$ for Power Sequencing

The \overline{SDOK} goes low when the step-down reaches regulation. Some microcontrollers with low-voltage cores require the high-voltage (3.3V) I/O rail not be powered up until the core has a valid supply. The circuit in Figure 13 accomplishes this by driving the gate of a PFET connected between the 3.3V output and the processor I/O supply.

Figure 14 shows a similar application where $\overline{AUX10K}$ gates 5V power to the CCD only after the +15V output is in regulation. Alternately, power sequencing can also be implemented by connecting RC networks to delay the appropriate converter ON_ inputs.

Using SCF for Full-Load Startup

The SCF output goes low only after the step-up reaches regulation. It can be used to drive a P-channel MOSFET switch that turns off the load of a selected supply in the

5-Channel Slim DSC Power Supplies

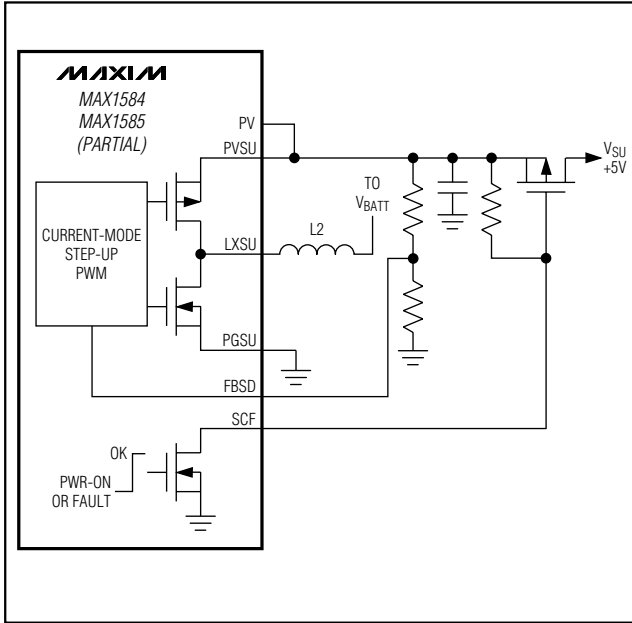

Figure 15. SCF controls a PFET load switch to disconnect all 5V loads on fault. This also allows full-load startup.

event of an overload. Or, it can remove the load until the supply reaches regulation, effectively allowing full-load startup. Figure 15 shows such a connection for the step-up output.

Setting SDO_{UT} Below 1.25V

The step-down feedback voltage is 1.25V. With a standard two-resistor feedback network, the output voltage can be set to values between 1.25V and the input voltage. If a step-down output voltage **less** than 1.25V is desired, it can be set by adding a third feedback resistor from FBSD to a voltage higher than 1.25V (the step-up output is a convenient voltage for this) as shown in Figure 16.

The equation governing output voltage in Figure 16's circuit is as follows:

$$0 = [(V_{SD} - V_{FBSD}) / R1] + [(0 - V_{FBSD}) / R2] + [(V_{SU} - V_{FBSD}) / R3]$$

where V_{SD} is the output voltage, V_{FBSD} is 1.25V, and V_{SU} is the step-up output voltage. Any available voltage that is higher than 1.25V can be used as the connection point for R3 in Figure 16, and for the V_{SD} term in the equation. Since there are multiple solutions for R1, R2, and R3, the above equation cannot be written in terms of one resistor. The best method for determining resistor values is to enter the above equation into a

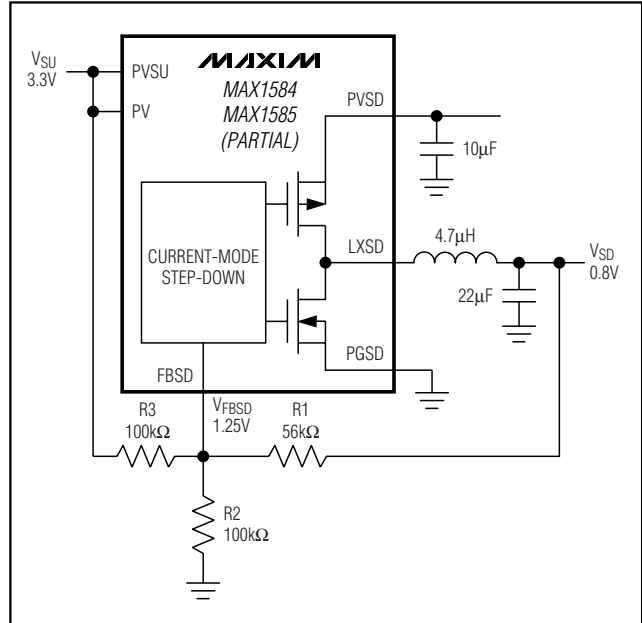

Figure 16. Setting PVSD for Outputs Below 1.25V

spreadsheet and test estimated resistor values. A good starting point is with 100kΩ at R2 and R3.

Designing a PC Board

Good PC board layout is important to achieve optimal performance from the MAX1584/MAX1585. Poor design can cause excessive conducted and/or radiated noise.

Conductors carrying discontinuous currents and any high-current path should be made as short and wide as possible. A separate low-noise ground plane containing the reference and signal grounds should connect to the power-ground plane at only one point to minimize the effects of power-ground currents. Typically, the ground planes are best joined right at the IC.

Keep the voltage-feedback network very close to the IC, preferably within 0.2in (5mm) of the FB_ pin. Nodes with high dV/dt (switching nodes) should be kept as small as possible and should be routed away from high-impedance nodes such as FB_. Refer to the MAX1584/MAX1585 evaluation kit data sheet for a full PC board example.

Chip Information

TRANSISTOR COUNT: 8234

PROCESS: BiCMOS

5-Channel Slim DSC Power Supplies

Package Information

(The package drawing(s) in this data sheet may not reflect the most current specifications. For the latest package outline information, go to www.maxim-ic.com/packages.)

MAX1584/MAX1585

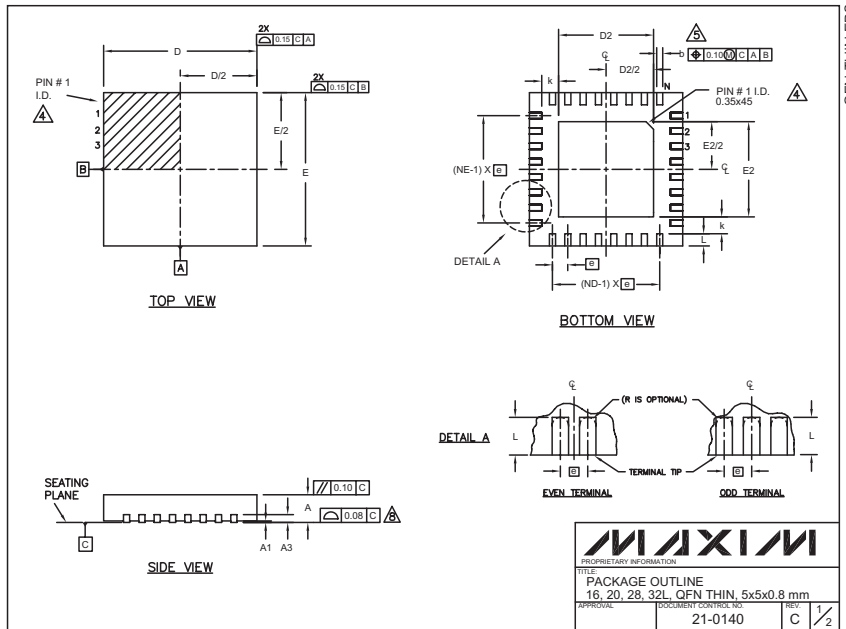

PKG. SYMBOL	COMMON DIMENSIONS											
	16L 5x5			20L 5x5			28L 5x5			32L 5x5		
	MIN.	NOM.	MAX.	MIN.	NOM.	MAX.	MIN.	NOM.	MAX.	MIN.	NOM.	MAX.
A	0.70	0.75	0.80	0.70	0.75	0.80	0.70	0.75	0.80	0.70	0.75	0.80
A1	0	0.02	0.05	0	0.02	0.05	0	0.02	0.05	0	0.02	0.05
A3	0.20 REF.			0.20 REF.			0.20 REF.			0.20 REF.		
b	0.25	0.30	0.35	0.25	0.30	0.35	0.20	0.25	0.30	0.20	0.25	0.30
D	4.90	5.00	5.10	4.90	5.00	5.10	4.90	5.00	5.10	4.90	5.00	5.10
E	4.90	5.00	5.10	4.90	5.00	5.10	4.90	5.00	5.10	4.90	5.00	5.10
e	0.80 BSC.			0.65 BSC.			0.50 BSC.			0.50 BSC.		
k	0.25	-	-	0.25	-	-	0.25	-	-	0.25	-	-
L	0.45	0.55	0.65	0.45	0.55	0.65	0.45	0.55	0.65	0.30	0.40	0.50
N	16			20			28			32		
ND	4			5			7			8		
NE	4			5			7			8		
JEDEC	WHHB			WHHC			WHHD-1			WHHD-2		

PKG. CODES	EXPOSED PAD VARIATIONS					
	D2			E2		
	MIN.	NOM.	MAX.	MIN.	NOM.	MAX.
T1655-1	3.00	3.10	3.20	3.00	3.10	3.20
T2055-2	3.00	3.10	3.20	3.00	3.10	3.20
T2855-1	3.15	3.25	3.35	3.15	3.25	3.35
T2855-2	2.60	2.70	2.80	2.60	2.70	2.80
T3255-2	3.00	3.10	3.20	3.00	3.10	3.20

NOTES:

- DIMENSIONING & TOLERANCING CONFORM TO ASME Y14.5M-1994.
- ALL DIMENSIONS ARE IN MILLIMETERS. ANGLES ARE IN DEGREES.
- N IS THE TOTAL NUMBER OF TERMINALS.
- THE TERMINAL #1 IDENTIFIER AND TERMINAL NUMBERING CONVENTION SHALL CONFORM TO JEDEC 95-1 SPP-012. DETAILS OF TERMINAL #1 IDENTIFIER ARE OPTIONAL, BUT MUST BE LOCATED WITHIN THE ZONE INDICATED. THE TERMINAL #1 IDENTIFIER MAY BE EITHER A MOLD OR MARKED FEATURE.
- DIMENSION b APPLIES TO METALLIZED TERMINAL AND IS MEASURED BETWEEN 0.25 mm AND 0.30 mm FROM TERMINAL TIP.
- ND AND NE REFER TO THE NUMBER OF TERMINALS ON EACH D AND E SIDE RESPECTIVELY.
- DEPOPULATION IS POSSIBLE IN A SYMMETRICAL FASHION.
- COPLANARITY APPLIES TO THE EXPOSED HEAT SINK SLUG AS WELL AS THE TERMINALS.
- DRAWING CONFORMS TO JEDEC MO220.
- WARPAGE SHALL NOT EXCEED 0.10 mm.

MAXIM

PROPRIETARY INFORMATION
TITLE: PACKAGE OUTLINE
16, 20, 28, 32L, QFN THIN, 5x5x0.8 mm REF.
APPROVAL: 21-0140 C 1/2

Maxim cannot assume responsibility for use of any circuitry other than circuitry entirely embodied in a Maxim product. No circuit patent licenses are implied. Maxim reserves the right to change the circuitry and specifications without notice at any time.

Maxim Integrated Products, 120 San Gabriel Drive, Sunnyvale, CA 94086 408-737-7600 _____ 29